



(12) **Øversettelse av
europeisk patentskrift**

(11) **NO/EP 3134581 B1**

NORGE

(19) NO

(51) Int Cl.

E02D 3/12 (2006.01)

E02D 3/00 (2006.01)

Patentstyret

(21)	Oversettelse publisert	2018.10.15
(80)	Dato for Den Europeiske Patentmyndighets publisering av det meddelte patentet	2018.05.16
(86)	Europeisk søknadsnr	15720257.3
(86)	Europeisk innleveringsdag	2015.03.28
(87)	Den europeiske søknadens Publiseringsdato	2017.03.01
(30)	Prioritet	2014.04.05, DE, 102014004936
(84)	Utpekte stater	AL ; AT ; BE ; BG ; CH ; CY ; CZ ; DE ; DK ; EE ; ES ; FI ; FR ; GB ; GR ; HR ; HU ; IE ; IS ; IT ; LI ; LT ; LU ; LV ; MC ; MK ; MT ; NL ; NO ; PL ; PT ; RO ; RS ; SE ; SI ; SK ; SM ; TR
(73)	Innehaver	Mikkelsen, Terje, Dybwadsgate 3, 0367 Oslo, Norge
(72)	Oppfinner	Mikkelsen, Terje, Dybwadsgate 3, 0367 Oslo, Norge
(74)	Fullmektig	ACAPO AS, Postboks 1880 Nordnes, 5817 BERGEN, Norge

(54)	Benevnelse	METHOD AND SOIL-STABILIZING MEANS
(56)	Anførte publikasjoner	EP-A1- 0 135 478, DE-A1-102004 031 039, DE-A1- 2 633 749, WO-A1-2005/121277

Vedlagt foreligger en oversettelse av patentkravene til norsk. I hht patentloven § 66i gjelder patentvernet i Norge bare så langt som det er samsvar mellom oversettelsen og teksten på behandlingsspråket. I saker om gyldighet av patentet skal kun teksten på behandlingsspråket legges til grunn for avgjørelsen. Patentdokument utgitt av EPO er tilgjengelig via Espacenet (<http://worldwide.espacenet.com>), eller via søkemotoren på vår hjemmeside her: <https://search.patentstyret.no/>

EP 3134581

**Method and soil-stabilising means for durable
soil stabilisation of frost-endangered fine-grain and mixed-grain
mineral soils for use as high load-bearing and frost-proof
foundation, sub-base, ballast and back-filling layers in structural
engineering, in road building and track construction and in earthwork and
civil engineering**

The object of the invention is a system technology consisting of the procedural instructions and an active substance used for stabilisation, called "soil-stabilising means" below, for use of frost-endangered fine-grain and mixed-grain mineral soils not suitable for building purposes and their conversion to durably resistant + frost-proof + high load-bearing foundation, sub-base, ballast and back-filling layers in the building and construction industry.

DE 26 33 749 A1 describes a soil-stabilising means for soil stabilisation based on epoxy resin esters. Alkyl sulphonate is indicated as plasticiser. After addition of the soil-stabilising means, compacting and in particular curing of the soil treated with epoxy resin ester must be effected to obtain a load-bearing, stabilised soil layer.

DE 44 28 269 A2 describes an impregnating soil-stabilising means for soil stabilisation based on polyvinyl esters. This document discloses plasticisers based on alkyl sulphonic acids.

DE 195 09 085 A1 discloses a plastisol composition. Plasticisers based on alkyl sulphonates are described, and it is shown that coatings of the general type may be made using this type of plastisol composition.

WO 1996/28505 A1 describes the use of alkyl sulphonic acid and esters thereof as plasticisers for coating soil-stabilising means.

However, the said soil-stabilising means for soil stabilisation have the disadvantage that a durably indestructible improvement of the soil properties of frost-endangered fine-grain and mixed-grain cohesive soils could hitherto not be proved.

DE 10 2004 031 039 A1 discloses a method for soil stabilisation, in which several additives in the form of polyelectrolytes, preferably polymers or copolymers based on acrylamide, and a hydraulic binder or a bitumen emulsion are applied to the soil to be stabilised and blended with the soil. Mechanical compacting of the soil is then effected.

The object of the invention is to improve a system technology for soil stabilisation consisting of a procedural instruction and a soil-stabilising means, with regard to the procedural sequence and the costs to achieve a durably indestructible improvement of the soil properties of fine-grain and mixed-grain, cohesive soils.

To achieve the object posed, a soil-stabilising means is proposed according to the technical teaching of independent claim 7. The method for using the soil-stabilising means is the object of independent claim 1.

A preferred area of use of the invention is the carrying out of the method and the use of the soil-stabilising means as a high load-bearing and frost-proof foundation, sub-base, ballast and back-filling layers in structural engineering, in road building and track construction and in earthwork and civil engineering.

The use applies generally to new building and also to renovations.

A particularly favourable application of the invention relates not only to street construction, but also to structural engineering. In structural engineering, foundation layers are used which are used as foundation padding for sub-bases of buildings. If in the foundation plane of a building, no load-bearing layer is present, the stabilising means of the invention is also used for stabilisation of the subsoil.

Due to the particular preparation of the foundation, sub-base, ballast and back-filling layers of the invention using the soil-stabilising means of the invention, the further advantage exists in that moisture rising from the subsoil and laterally penetrating moisture are stopped. Seepage water layers are reliably stopped.

Hence, stable back-filling layers in structural engineering may also be produced which serve, for example for filling dug-out excavations.

5 Such stabilised back-filling layers are also used in pipeline construction for covering the pipelines incorporated in the ground.

10 Hence, the advantage exists that the existing soil removed from the excavation or from the pipe ditch does not have to be removed without replacement, but it may be incorporated again with after-treatment using the soil-stabilising means of the invention.

15 Existing constructions may also be drained in that the soil incorporated earlier in the excavation region is dug out in sections and after treatment with the soil-stabilising means of the invention has been effected, incorporated again.

20 A further important application of the present invention lies in the treatment of water ditches, in which the bed or the banks are in danger of erosion. Even in this case the bed or the banks of water ditches may be protected and sealed against erosion by treatment with the soil-stabilising means of the invention.

25 The soil-stabilising means of the invention is even suitable for producing block bricks or other solid building bodies in modular design. Hence, according to a development of the invention provision is made that a soil treated with the stabilising means pressed into shapes and subsequently the building blocks thus produced, building bodies or other modular components are used for further construction in structural or civil engineering. These elements are then particularly water-tight, highly loadable and protected against the penetration of moisture.

30 The use of the soil-stabilising means of the invention is also suitable for dyke construction or dyke reconstruction. Both the entire building body of a dyke or also only water-stressed parts of a dyke (for example also the sealing skirt) are protected against penetration of pressurised water.

An important feature of the soil-stabilising means is that a durable reduction of the water-binding forces of the fine soil constituents of these soils is possible due to a soil-stabilising means which acts as an ion exchanger and catalyst.

- 5 The soil-stabilising means used is a slightly water-soluble, clear liquid, the chemical composition of which is a mixture of different sulphonic acids + special additives + water. The viscosity is oily.

- 10 A main constituent of the active substances of the soil-stabilising means is a mixture of different sulphonic acids, which have as a common feature the functional group $-\text{SO}_3\text{H}$, linked to a water-repellent organic constituent R. The representation is: R-SO₃-H.

- 15 The sulphonic acids disassociate in water. The soil-stabilising means of the invention acts in the soil as an ion exchanger and catalyst.

- 20 The soil-stabilising means ensures that the hydrogen ions H^+ adhesively bound to the surface of the soil particles, (and hence the water attached to these ions via hydrogen bridges) are expelled and replaced by (+) metal ions, for example Na^+ ; K^+ ; Mg^{++} ; Ca^{++} ; Al^{+++} , present in the water shell;

- 25 Hence, a large part of the firmly bound adhesion water is removed from the surface of the soil particles in that it is converted to free pore water. This free water may escape easily from the soil due to drying or may migrate into the pore space between the soil particles.

- 30 The soil-stabilising means of the invention furthermore ensures that the (+) metal ions bound to the soil particles can no longer attach hydrate water in that the acid radical ions present in the soil-stabilising means are combined with the (+) metal ions. It is thus a reduction of the adsorption water shell due to an ion exchange mechanism.

A further effect takes place by hydrophobing ("water-repelling impregnation") of the soil particles.

The acid radical ions present in the soil-stabilising means and being attached to the metal ions are linked to a hydrophobic organic component. The hydrophobic constituents ensure that in the compacted soil, water may no longer be transported in the pore space.

5

The hydrogen ions H^+ becoming free during dissociation in the soil-stabilising means of the invention react directly with the hydroxyl ions OH^- present in the water shell to form hydronium ions H_3O^+ and in a further step to form water H_2O . Hence, the acid effect is eliminated and neutralisation has taken place.

10

The chemical reactions which are effected in the soil by the soil-stabilising means of the invention are irreversible. The change in the soil properties is thus durable. The adsorption water shells reduced by the action of the soil-stabilising means may no longer be built up.

15

Due to the durably reduced water shells around the soil particles, the soils treated with the soil-stabilising means in the condition of optimum water content in the soil required for compacting, with the same compacting work, may be compacted to higher dry density than soil not treated with the soil-stabilising means.

20

Due to the more compact position of the soil particles with respect to one another, existing molecular close-range action forces are amplified between the soil particles which lead to an increase in the strength and hence the load-bearing capacity. This effect is no longer lost and thus remains durable.

25

The hydrophobic (water-repellent) constituents of the soil-stabilising means ensure that in a soil treated with the soil-stabilising means according to the use instructions and compacted, capillary water rise is stopped and the penetration of water into the compacted soil body is in general prevented.

30

During freezing of the soil, the water supply from below into the freezing zone is thus lacking, the frost cannot effect structural changes, the soil is frost-proof.

The majority of loose rocks occurring on the earth surface in many counties of the world are fine-grain and mixed-grain mineral soils which are not suitable for building purposes due to their content of fine materials and the water sensitivity and frost sensitivity associated therewith, and therefore for building purposes, but in particular
5 in conventional road building and track construction, have to be exchanged for frost-proof and water-insensitive mineral mixtures.

This relates to the soil types: clay, coarse clay (also designated as silt or very fine sand), mineral mixtures of stones, gravel or sand in each case with admixtures of
10 more than 15 mass % of coarse clay and/or clay: such as for example sand containing clay, sand containing coarse clay, sand containing clay and coarse clay, gravel sand containing clay, gravel sand containing coarse clay, gravel sand containing clay and coarse clay, loam (mixture of fine sand + coarse clay + clay), natural or broken rock mixtures.

15

The soil-stabilising means of the invention may be used generally in the building and construction industry, in particular in road building and track construction, in earthworks and foundations for the purpose of stabilising frost-endangered, fine-grain and mixed-grain loose rocks. These mineral soils no longer have to be
20 removed from the building site, as hitherto, and be replaced with frost-proof mineral mixtures (as frost-proofing layer, ballast sub-base layer, gravel sub-base layer). Rather the soil resulting at the building site is treated with the soil-stabilising means in situ and after subsequent compacting converted to durably resistant + frost-proof + high load-bearing construction layers.

25

Classification in terms of soil mechanics of the suitable soils to be treated with the soil-stabilising means:

For optimum success when using the soil-stabilising means, the mineral soils to be
30 used must have the following properties in terms of soil mechanics A + B + C + D, which are determined in laboratory investigations relating to soil mechanics. The soils to be found predominantly are suitable for stabilisation with the soil-stabilising means.

Soils with deviating characteristic values may be pre-treated specifically and then likewise stabilised using the soil-stabilising means.

- 5 A) Proportion of fine soil particles with D equivalent < 0.06 mm : > 15 mass % relative to the dry mass; measurement of the proportion by sieving or by determining the grain-size distribution in the fine range, for example by sedimentation analysis in the laboratory, or by other conventional methods for determining the grain-size distribution;
- 10 In mineral soils in which the proportion of fine particles is less than 15 mass %, other mineral soils with significantly more proportions of fine materials, for example clay or loam, may be mixed in, which have to be disposed of at other building sites so that the proportion of fine materials of the total mass of the mixed soils as a result is more than 15 mass %. Recycling materials with high proportion of fine material,
- 15 for example power station ash, are also suitable as additives. The advantage lies in being able to provide these materials which cannot be used for other building purposes very cost-effectively and hence do not have to be disposed of as waste by other users.
- 20 B) Plasticity > 10
Plasticity in soil mechanics is the difference between the water content at the liquid limit and the water content at the plastic limit.
- If the plasticity is < 10 , suitable additives according to part A may be mixed in until
- 25 suitability is achieved.
- C) The proportion of organic admixtures (for example humus) must be less than 4 mass %, relative to the dry mass.
- 30 D) The pH value of the soil must be greater than pH 6, if it is less than pH 6, the soil may be rendered suitable by special pre-treatment.
1. Function of the soil particles
All soil particles are surrounded by a water shell.

Coarse soil particles have a low specific surface area and for every mass unit may bind only a low quantity of water to the surface. Pressure, friction and dovetailing predominate during energy transmission between the grains.

- 5 Fine soil particles have a large specific surface area and for every mass unit may bind a large quantity of water to the particle surface. Water content-dependent cohesion predominates. In the case of water access, the water shells around the soil particles are enlarged and press the particles mutually away from one another, hence the binding forces are reduced, the strength and load-bearing capacity of
- 10 fine-grain soils is lost with increasing water content.

In the case of mixed-grain soils with a proportion of fine material of > 15 mass %, the soil properties are determined predominantly by the surface-active properties of the fine materials.

15

The proportions and distribution of the individual masses of the individual grain-size fractions of the total mass of a soil sample of a mineral soil is designated as grain-size distribution.

- 20 It is an important working means for assessing mineral soils with regard to their properties relating to soil mechanics for building purposes.

Separation of the grain fractions is effected for purely coarse-grain soils by sieve analysis and for fine-grain soils by sedimentation analysis.

25

Distribution of the grain fractions is determined for mixed-grain soils, which contain both coarse-grain and fine-grain portions, by a combination of sieve analysis and sedimentation analysis.

- 30 The diagrammatic representation of grain size distribution is preferably effected as a cumulative line.

2. About the mode of operation of water in fine-grain soils

Drying effects a reduction of the water shells around the soil particles, which is designated as “shrinking” of the soil, which corresponds to a convergence of the soil particles.

- 5 An increase of the binding forces between the particles due to reduced distance from one another and due to rising of the suction tension of the “meniscus water” at the contact points of the particles is thus effected. A rise in strength and load-bearing capacity of the fine-grain soils is associated therewith.
- 10 In the case of water access, enlargement of the water shells – so-called “swelling” of the soil and hence mutual “pressing away from one another” of the soil particles is effected via the water shells. This produces a reduction of the binding forces between the particles due to increased distance from one another and due to reduction of the suction tension of the water at the contact points of the particles.
- 15 This produces a loss in strength and load-bearing capacity of the fine-grain and mixed grain soils.

The invention starts here which achieves a permanent reduction of the water shells during mixing-in of the soil-stabilising means of the invention into the soil.

- 20 Enlargement of these water shells is no longer effected on renewed water access.

An improved mutual convergence of the soil particles due to compacting because of reduced water shells is thus guaranteed.

- 25 Likewise an increase of the binding forces between the particles is effected by reduced distance from one another and by rising of the suction tension of the “meniscus water” at the contact points of the particles. This produces a rise in strength and load-bearing capacity of the fine-grain soils.
- 30 This produces more compact packing of the particles because of the reduced water shells and density change and loss in strength are no longer produced in the case of water access and in the case of frost.

3. About the mode of operation of the soil-stabilising means in fine-grain soils as catalyst and ion exchanger

5 The soil-stabilising means is not a binder like lime or cement. When using the soil-stabilising means in the soil, no crystal structures are built up between the soil particles. The increase in strength when using the soil-stabilising means results from the closer convergence of the soil particles during soil compacting due to a considerable and non-reversible reduction of the size of the adsorbed water shells surrounding the particles.

10

There are thus three different function mechanisms:

3.1. Reduction of the adsorption water shell by exchange mechanism 1

15 The soil-stabilising means ensures that a large part of the hydrogen ions H^+ bound to the surface of the soil particles, (and hence the further water attached to these ions via hydrogen bridges) are replaced by (+) metal ions, for example Na^+ ; K^+ ; Mg^{++} ; Ca^{++} ; Al^{+++} , present in the water shell;

20 Hence, a large part of the firmly bound adhesion water is released from the surface of the soil particles, in that it is converted to free pore water. This free water may escape easily from the soil due to drying or is distributed in the pore space between the soil particles.

3.2. Reduction of the adsorption water shell by exchange mechanism 2

25 The soil-stabilising means further ensures that the (+) metal ions bound to the soil particles can no longer attach hydrate water in that instead the acid radical ions (sulphate group) present in the soil-stabilising means are combined with the (+) metal ions.

30 3.3 Hydrophobing ("water-repellent impregnation")

The acid radical ions (sulphate group) present in the soil-stabilising means and being attached to the metal ions are linked to a hydrophobic organic component. This ensures that the fine soil particles lose the ability to take up water at the particle

surface and that the soil treated with the stabilising means loses the ability to transport water in the capillaries.

3.4 Neutralisation

- 5 The hydrogen ions H^+ which become free during dissociation in the soil-stabilising means react directly with the hydroxyl ions OH^- present in the water shell to form hydronium ions H_3O^+ and in a further step to form water H_2O . The acid effect is thus eliminated.
- 10 4. Summary of the system technology of the invention for durable and frost-proof stabilisation of fine-grain and mixed-grain mineral soils using the example of road building and track construction
- 4.1 Test soil with regard to suitability for using the system technology
- 15 4.2 Scarify and loosen surface of the ground surface
- 4.3 Introduce into the soil and mix soil-stabilising means diluted with water in several working steps
- 20 4.4 Compact soil in the condition of optimum water content for compacting
5. Detailed system technology of the invention for durable and frost-proof stabilisation of fine-grain and mixed-grain mineral soils using the example of road
- 25 building and track construction
- 5.1 Investigation of the subsoil
for the roads and tracks to be built, carrying out of the suitability test developed for this system technology, and of selected investigations in the laboratory relating to
- 30 soil mechanics, particularly for determining the proportion of fine materials in the soil with a particle diameter < 0.06 mm for establishing the application quantity of the soil-stabilising means, and for determining an optimum water content required for compacting the soil.

5.2 Mark out gradients and profile of the road (of the track)

Required equipment: measuring equipment

5.3 Remove vegetation, humus + soil layers with a proportion > 4% of organic admixtures.

Required equipment, for example earth mover, or bulldozer, or grader or terrace miller

5.4 Soil analysis at the building site,

10 removal of a soil sample to determine the current water content of the soil, removal depth below ground surface corresponding to the intended working depth of the soil mixing miller, usually up to 30 cm deep

Required equipment: suitable device for rapid determination of the water content of mineral soils.

15 Result of the test is the current water content w in the soil up to the working depth of the miller and serves to calculate the quantity of water with which the soil-stabilising means is diluted and introduced into the soil.

5.5 Produce coarse ground surface, according to the plan models,

20 Required equipment: grader

Transverse gradient must run parallel to the gradient of the later cover layer.

Later, after the soil-stabilising means has been distributed on the loosened ground surface, greater soil movements and soil displacements may no longer take place, so that the depth of soil treatment with the soil-stabilising means is not reduced in

25 places.

5.6 Scarify and loosen the ground surface

about 10 cm deep for uniform take up of the soil-stabilising means

Required equipment: for example scarifier or ripper or cultivator or spring-tooth

30 harrow or disc harrow or miller to 10 cm deep.

5.7 Measurement of the current water content in the soil, determination of the quantity of water with which the soil-stabilising means is diluted to be introduced into the soil, so that after introducing the working solution, consisting of the soil-

stabilising means + water, the water content in the soil lies optimally no more than 2% above the optimum water content w required for best possible compacting of the soil, this water content was determined in the laboratory before the start of building.

5

5.8 Produce the 1st part quantity of a working solution consisting of the soil-stabilising means + water in a tank and mix for 1st working step, determine quantity of soil-stabilising means to be introduced as a function of the proportion of fine constituents $D < 0.06$ mm in the soil.

10 Alternatively: provide calculated quantity of the soil-stabilising means + water separately for mixing only during introduction into the soil.

5.9 introduce the 1st part quantity of working solution comprising the soil-stabilising means + water uniformly onto the previously loosened ground surface in the soil

15

Introduction variant 1: the soil-stabilising means is mixed with water to start with in a movable tank and applied to the ground surface in the free gradient via a distribution pipe with discharge nozzles, the issue quantity from the distribution pipe determines the rate of movement

20

Introduction variant 2: the soil-stabilising means is mixed with water to start with in a movable tank, and applied to the ground surface via pumps and further via a distribution pipe with discharge nozzles, the pump conveying quantity and the rate of movement are regulated according to the intended application quantity

25

Introduction variant 3: the soil-stabilising means is mixed with water to start with in a movable tank, and introduced into the soil via pumps and further via a distribution pipe with discharge nozzles within the soil mixing miller during the milling process, the pump conveying quantity and the rate of movement of the miller are regulated according to the intended application quantity.

30

Introduction variant 4: the quantity of water required for dilution is provided in a movable tank, the soil-stabilising means is placed on the tank vehicle in a supply barrel (200 litre barrel or 1,000 litre euro-container) or on a trailer coupled to the

tank vehicle. Both components are conveyed separately via separate pumps into a mixing container and further introduced into the soil via a distribution pipe with discharge nozzles, the pump conveying quantities and the rate of movement of the tank vehicle are regulated according to the intended application quantities, wherein
5 the dilution ratio between the soil-stabilising means and water may be changed during introduction into the soil.

Introduction variant 5: mix the soil-stabilising means and about 10 times the quantity of water in a portable pressure spray and introduce the mixture by hand into the soil
10 to be treated, for small surfaces and small soil quantities and for selected regions with extremely high natural water content;

5.10 Comminute soil and mix intensively with the soil-stabilising means, working depth of the soil mixing miller minimum up to 30 cm below ground surface, with track
15 overlapping.

Required equipment: Suitable soil mixing miller

5.11 Level the surface, level out undulations of the working tracks of the miller, loosen solidified points in the subsoil, particularly at the edges of the working tracks
20 of the soil mixing miller; thus mix the soil further, in several crossings.

Required equipment: ripper or cultivator or spring-tooth harrow or disc harrow, or soil mixing miller

5.12 Produce the 2nd part quantity of a working solution consisting of the soil-stabilising means + water in a tank and mix for 2nd working step, determine
25 requirement of soil-stabilising means + water as a function of proportion of fine constituents $D < 0.06$ mm in the soil.

Alternatively: provide calculated quantity of the soil-stabilising means + water for mixing during introduction into the soil.

30

5.13 introduce into the soil the 2nd part quantity of working solution comprising the soil-stabilising means + water uniformly onto the loosened ground surface.

Variant for introduction as under point 5.9

5.14 Intensively mix soil further, working depth up to 30 cm below ground surface, with track overlapping.

Required equipment: Suitable soil mixing miller

5 5.15 Level surface, level out undulations of the working tracks of the miller, loosen solidified points in the subsoil, particularly at the edges of the working tracks of the soil mixing miller; thus mix the soil further, in several crossings.

Required equipment: ripper or cultivator or spring-tooth harrow or disc harrow, soil mixing miller

10

5.16 Monitor the current water content w in the soil before compacting:

If the current water content w is higher than the optimum water content determined w_{opt} for compacting, drying and further mixing of the soil is required until $w = w_{opt}$.

15 If the water content w is less than the optimum water content determined for compacting, moistening and further mixing of the soil is required until $w = w_{opt}$.

5.17 Produce fine ground surface.

Required equipment: grader and devices for gradient measurement

20

5.18 Compact soil from the surface of the ground surface, compacting sequence always from the edge to the middle of the road/track, preferably by stage-wise introduction of the compacting energy. This is carried out starting with light compacting equipment, for example with vibrating plate compacters. Continuing with heavy compacting equipment, for example by means of rollers with > 15 tonnes of dead weight without vibration, then continuing compacting with rollers with > 15 tonnes of dead weight with vibration and final compacting with heavy rubber-wheel roller.

25

30 5.19 During compacting with rollers > 15 tonnes of dead weight with vibration, an approximately 5 cm compacted levelling layer comprising a coarse broken, frost-proof rock mixture without fine proportions $D < 0.06$ mm, for example chippings 16/32 mm, is applied to the earth ground surface and distributed in uniform layer thickness.

This has to be effected at a time when the broken coarse grains can still partly be pressed into the ground surface of the stabilising layer.

(The levelling layer has the task of ensuring, for directly used roads and tracks without additional bound cover layer, friction between the wheels of the vehicles and the solid smooth compacted surface of the stabilising layer.

For roads and tracks which are covered with an additional cover layer in a further working step, this levelling layer ensures friction and dovetailing between cover layer and the surface of the compacted stabilising layer.)

10 5.20 apply the 3rd part quantity of the working solution comprising the soil-stabilising means + water uniformly to the levelling layer without mixing in

15 5.21 Conclusion of compacting when the measurements according to 5.21; 5.22 and 5.23 prove adequate compacting, otherwise further compacting using heavy compacting equipment according to 5.18

5.22 Determination of the dry density achieved with a sampling tube (for fine-grain soil without stones) or for example with the soil densitometer or other suitable measuring methods (for soil with stones)

20

5.21 Measurement of the load-bearing capacity achieved on the compacted ground surface, 24 hours after conclusion of compacting, with the static plate load equipment,

determination of the load-subsidence curve for stage-wise load introduction of the static loads on a loading plate of 30 cm diameter

25

Measured result = EV2 [MPa]

5.22 Measurement of the load-bearing capacity achieved on the compacted ground surface, 24 hours after conclusion of compacting, with the dynamic plate load equipment,

30

determination of the subsidence depth and subsidence rate of a loading plate of 30 cm diameter when hit by a falling weight

Measured result = EV dyn [MPa]

A durably high load-bearing frost-proof lower sub-base layer is produced in road building with these working steps from the frost-endangered fine-grain and mixed-grain soil of the subsoil, prepared for application of a bound cover layer comprising asphalt or concrete.

- 5 For secondary roads and economy tracks, this thus constructed stabilised layer may be used directly without additional cover layer.

6. Effects of using the soil-stabilising means

- 10 The new properties of the soils treated with the soil-stabilising means after compacting to form construction layers in road building and track construction lead to high durable and indestructible strength and load-bearing capacity, and to durable resistance to the action of water and frost.

- 15 Measurable swelling and shrinkage no longer take place, no volume changes or deformations of the compacted construction layers. A uniform low water content in the compacted soil, independently of the ambient moisture, is guaranteed. The capillary water rise is durably stopped. Durable frost resistance is thus provided.

- 20 The further advantages of the soil-stabilising means technology in road building and track construction are as follows:

- No exchange of unsuitable frost-endangered soil required on the building site. Hence, release, recovery, loading, transporting away of non-usable soil including deposition in a soil tip is omitted.
- 25
- Recovery, loading, transporting and the incorporation of certified, frost-proof rock mixtures for use as sub-base layers is omitted;
 - These two savings produce a reduction of the building costs and a reduction of the building time, and a reduction of the energy consumption/reduction of the CO₂ output
- 30
- In addition, considerable advantages for the national economy are produced, because due to the omission of the considerable consignments, the existing highways are loaded less and thus remain usable for longer.

The use of the soil-stabilising means can be applied with considerable advantage in areas which do not have a suitable rock deposit to recover frost-proof, load-bearing rock mixtures for sub-base layers.

- 5 The technology can be used equally advantageously for strengthening highways in areas with permafrost soils which in summer thaw up to greater depth and thus soften and hence lose their load-bearing capacity in the subsoil.

10 The inventive object of the present invention can be seen not only from the object of the individual patent claims, but also from the combination of individual patent claims with one another.

15 All details and features disclosed in the documents, including the abstract, in particular the spatial design shown in the drawings, are claimed as important for the invention, provided they are novel individually or in combination with respect to the state of the art.

20 The invention is illustrated in more detail below using drawings showing only one execution path. Further features and advantages of the invention which are important for the invention can thus be seen from the drawings and their description.

The following are shown:

25 Figure 1: the production of a road substructure according to the basic technology of the invention

Figure 2: the production of a road substructure as according to Figure 1, wherein additionally soil with high proportion of fine material is added to the soil with low proportion of fine material to be stabilised

30

Figure 3: the production of a road substructure with the additional incorporation of an existing damaged cover layer

Figure 4: the production of a road substructure with the additional incorporation of soil, recovered from a ditch in the vicinity of the building site

5 Figure 5: the production of a road substructure with addition of soil without or with low proportion of fine materials of less than 15 mass %, wherein the resulting soil has a very high proportion of fine materials.

10 Figure 6: the production of a road substructure with addition of recycled building material.

Figure 7: the production of a road substructure with incorporation of soil pre-treated with the soil-stabilising means from the earth depot

15 Figure 8: the method steps according to the invention for producing a road substructure

Figure 9: the method steps for producing a road substructure according to the state of the art

20 Figure 1 shows in method steps a-j, the step-wise build-up and the production of a road subsoil for producing a road using the system technology of the invention.

25 Starting from an upper edge 31 of the substructure, the substructure should be formed as a fine-grain and mixed-grain soil in the subsoil. The proportion of fine soil particles with $D < 0.06$ mm is, for example more than 15 % of the dry mass. Such a substructure 1 would be in danger from the influence of frost and water, and therefore it is not possible to apply a cover layer 10, for example comprising asphalt, to such a substructure.

30 For this reason according to method step b, the substructure 1 is first scarified and loosened up to a layer depth 2 of preferably 10 cm below ground surface in arrow directions 6, combined with a volume increase due to loosening.

In method step c, the soil-stabilising means 3 (abbreviation: SSM) of the invention is applied to this layer in arrow direction 4 over a large surface area and taken up by the loosed layer.

5 In method step d, the substructure now thus soaked with the soil-stabilising means 3 in the surface region is milled and mixed in arrow directions 6 up to a layer depth of preferably 30 cm, so that the soil-stabilising means is distributed uniformly as far as the depth of 30 cm in the subsoil.

10 In method step e, the soil-stabilising means 3 is distributed a further time onto the loosened surface in arrow direction 4 uniformly on the surface, and taken up in the region of the soil close to the surface.

In method step f, again the entire stabilising layer 5 soaked with the soil-stabilising
15 means is mixed and dried, whereby the total quantity of soil-stabilising means 3 introduced is distributed uniformly up to a depth of 30 cm in the subsoil.

In method step g, the converted stabilising layer 5 is now strongly compressed using
20 a compacter 7, whereby there is volume compacting and a novel loadable subsoil in the form of the now existing stabilising layer 5 is produced.

In method step h, a levelling layer 8 is applied to the converted stabilising layer 5
and in method step i, sprayed and soaked with the soil-stabilising means 3 of the
invention in arrow direction 4 over a large surface area.

25 Due to further compacting using the compacter 7, in method step j, the levelling layer 8 is partly pressed into the underlying and compressed stabilising layer 5.

A high-strength, frost-proof and stable substructure for the subsequent build-up of
a road cover, consisting of an upper bound sub-base layer 34 and a cover layer 10,
30 is thus produced (see the later figures).

Figure 2 starts from a different initial situation, where it is assumed that starting from a substructure 1 with less than 15 mass % of fine proportions with $D < 0.06$ mm, in method step b, an application of mineral soil brought over with a high proportion of

fine material (for example clay, loam), designated below as loam layer 9, onto the substructure is now effected.

5 In method step c, this loam layer 9 is sprayed over a large surface area with the soil-stabilising means 3 of the invention in arrow direction 4, so that the soil-stabilising means 3 penetrates into the loose layer.

10 In method step d, the milling and mixing up to a depth of 30 cm in arrow directions 6 is effected, whereby a coherent uniform and homogeneous stabilising layer 5 is produced.

15 The stabilising layer 5 is treated once again with the soil-stabilising means 3 in method step e, and in method step f, in arrow directions 6 once again mixed thoroughly and dried.

20 In method step g, compacting and compression of the stabilising layer soaked with the soil-stabilising means 3 is effected via the compactor 7, and in method step h, a levelling layer 8 is applied which in method step i, in turn is sprayed over a large surface area with the soil-stabilising means 3 in arrow direction 4.

In method step j, the levelling layer 8 is then compacted using the compactor 7 and hence a composite with the compacted stabilising layer 5 produced.

25 Finally, in method step k, an upper bound sub-base layer 34 and a cover layer 10, which corresponds to a conventional road covering, is applied to the thus produced stabilising layer 5 with a levelling layer 8 lying thereon.

30 It is noted that in the preceding exemplary embodiments 1 to 2 and in all other subsequently outlined exemplary embodiments 3 to 7, the same reference numbers and the same working steps are used for the same parts.

Therefore the exemplary embodiment according to Figure 3 differs from the preceding exemplary embodiments according to Figure 1 and 2 only in that in Figure 3 it is assumed that a road with the upper edge 32 and a cover layer 10 is provided,

wherein this cover layer 10 may consist of asphalt or concrete. This cover layer 10 is damaged, and a new road with the substructure of the invention must be produced from this damaged road.

- 5 It is further assumed in Figure 3 in method step a (initial situation) that a traditional sub-base layer 11 is present below the damaged cover layer 10 and this sub-base layer 11 sits on a conventional subsoil 1.

10 To produce a new road, in method step b, the existing damaged cover layer 10 and the sub-base layer 11 together with the subsoil 1 is first scarified in arrow directions 6 and mixed thoroughly. The layer depth 2 is thus indicated, for example at 30 cm below the upper edge 32 of the old cover layer.

15 In method step c, the soil-stabilising means 3, which is taken up by the loosened soil in the surface region, is then applied over a large surface area in arrow direction 4 to the thus thoroughly mixed and homogenised layer.

In method step d, the stabilising layer 5 is milled in arrow directions 6 and thoroughly mixed, whereby the soil-stabilising means is distributed uniformly in the layer.

20 In method step e, the soil-stabilising means 3 is applied over a large surface area in arrow direction 4 a further time to the thus prepared stabilising layer 5, and in method step f, in turn mixing and simultaneous drying of the thus homogenised stabilising layer 5 soaked with the soil-stabilising means is effected.

25 In method step g, compacting using the compactor 7 is now effected, and in method step h, application of a levelling layer 8 is effected.

In method step i, renewed application of a soil-stabilising means 3 is effected in arrow direction 4 onto the levelling layer 8 to seal the surface.

30

In method step j, compression of the levelling layer 8 and partial pressing into the stabilising layer 5 is effected using the compactor 7 and the now finally prepared substructure is covered, in method step k, with a conventional upper bound sub-

base layer and a cover layer comprising asphalt or concrete or the like. A new road is thus provided with a high-strength, frost-proof and stable substructure.

5 In the exemplary embodiment according to Figure 4, it is assumed that additionally large stones 12 and blocks are also present in the frost-endangered subsoil 1 as according to Figures 1 to 3. They are firmly embedded in the fine soil particles and should not be comminuted so as not to destroy the compact structure in the subsoil and so as to protect the miller.

10 This subsoil is a frost-endangered fine-grain and mixed-grain soil just as in Figures 1 to 3, in which the proportion of fine soil particles with $D < 0.06$ mm is $>$ than 15 % of the dry mass.

15 The high water permeability of the subsoil present in this example makes it possible to distribute uniformly the soil-stabilising means 3 without mechanical thorough-mixing in the lower region of the stabilising layer 5.

20 For the said reason, first loosening of the surface with a scarifier 14, which is moved in arrow direction 15 along the surface of the substructure up to a layer depth 13 of, for example 5 cm below the upper edge 31, is effected in method step b.

25 In method step c, the soil-stabilising means 3 of the invention is sprayed in arrow direction 4 onto the loosened surface. Due to the action of gravity, it penetrates in arrow direction 17 into the substructure 1 with the stones and soaks it uniformly in method step d without destroying the compact structure in the subsoil.

30 In method step e, a suitable soil is recovered from a ditch and passed through a sieve 19 with a mesh width of 50 mm in arrow direction 18, wherein the stones 12 with $D > 50$ mm are held back and do not have to be comminuted later. Only the soil portions with a diameter of < 50 mm leave the sieve.

In method step f, the fines 20 with $D < 50$ mm are poured in arrow direction 21 onto the previously loosened existing ground surface treated with the soil-stabilising means and distributed in uniform layer thickness.

In method step g, the poured layer is soaked with the soil-stabilising means 3 of the invention in arrow direction 4, wherein the soil-stabilising means is taken up by the soil pores in the upper region of the filling.

5 In method step h, this poured layer 22 soaked with the soil-stabilising means is mixed and dried and in method step i, compacted using the compactor 7. In method step j, a levelling layer 8 is then applied which in method step k, is further impregnated and soaked with the soil-stabilising means 3 of the invention in arrow direction 4.

10

Finally, in method step l, the thus prepared layers 8 + 22 + 5 soaked with the soil-stabilising means 3 are compacted using a compactor 7, whereby a frost-proof and highly loadable substructure is provided for application of a first sub-base layer 34, for example asphalt sub-base layer, and a cover layer 10, for example comprising
15 asphalt or concrete.

15

In the exemplary embodiment according to Figure 5, it is assumed that for a subsoil 1, which consists of a fine-grain and mixed-grain soil, a very high proportion of the fine soil particles with $D < 0.06$ mm and considerably more than 15 % of the dry
20 mass is present. For example a high proportion of clay may be present. Such a subsoil 1 would be endangered by the influence of frost and water.

20

For this reason, the invention according to the exemplary embodiment according to Figure 5 method step b makes provision that first a build-up layer 23 with a low
25 proportion of fine material is applied above the upper edge 31. This build-up layer preferably has particles with a diameter $D < 0.06$ mm and $<$ than 15 mass % proportion for lowering the soil present in the subsoil with very high fine proportion.

25

In method step c, the soil-stabilising means 3 is applied to this loosened existing
30 build-up layer 23 in arrow direction 4, which soaks the build-up layer 23 in arrow direction 17, and in method step d, the build-up layer soaked with the soil-stabilising means is mixed into the subsoil up to depth 2 and the entire stabilising layer 5 is mixed and comminuted.

30

In method step e, repeated application of the soil-stabilising means 3 is effected in arrow direction 4 onto the loosened surface.

5 Then in method step f, the stabilising layer 5 is in turn mixed and thus dried so that the total quantity of soil-stabilising means is distributed uniformly in the stabilising layer, and in method step g, compacted using the compactor 7.

In method step h, a levelling layer 8 is applied and in method step i, in turn soaked and impregnated with the soil-stabilising means 3 in arrow direction 4.

10

In method step j, the structure thus produced is compacted once again using the compactor 7 so that the levelling layer is partly pressed into the previously compacted stabilising layer, and finally in method step k, a conventional upper bound sub-base layer 34, for example as an asphalt sub-base layer, and a cover
15 layer 10, for example comprising asphalt or concrete, is applied to the levelling layer 8, which is now firmly and homogeneously combined with the stabilising layer 5.

The exemplary embodiment according to Figure 6 differs from the previously cited exemplary embodiments according to Figures 1 to 5 only in that recycling material
20 is also additionally added to the ground surface of the existing subsoil 1. Such a recycling material may be, for example non-loaded building rubble, filter ash, broken bricks, broken concrete or rubble stones.

In method step a, the starting point is therefore a frost-endangered substructure 1,
25 as also indicated as starting point for the previously cited exemplary embodiments.

In method step b, an application of recycling material 24, which may optionally also comprise stones 12, broken bricks, broken concrete and rubble stones, is effected.

30 In method step c, a first application of soil-stabilising means 3 onto the layer of recycling material 24 is carried out in arrow direction 4, wherein the soil-stabilising means penetrates into the applied loose layer in arrow directions 7 and hence a homogeneous stabilising layer 5 is generated in method step d when this stabilising layer is milled and mixed.

In method step e, a soil-stabilising means 3 is applied to the thus homogenised stabilising layer 5 in arrow direction 4, and in method step f, in turn this layer soaked with the soil-stabilising means is mixed and dried.

5

In method step g, compacting using the compactor 7 is effected, and then in method step h, a levelling layer 8 is applied.

10

In method step i, the soil-stabilising means 3, which soaks the levelling layer 8 and seals the surface, is applied to the levelling layer 8 for the third time.

15

Finally, in method step j, compacting of the stabilising layer 5 and the levelling layer 8 is carried out so that in method step k, a conventional upper bound sub-base layer 34, for example as an asphalt sub-base layer, and a cover layer 10, or example comprising asphalt or concrete, may be applied to the thus homogenised substructure 5, 8.

20

The exemplary embodiment according to Figure 7 assumes that the entire soil is produced in an earth depot for a substructure to be newly constructed. It is therefore a fine-grain and mixed-grain frost-endangered soil which is supplied to an earth depot or a warehouse. The proportion of fine soil particles $D < 0.06$ mm preferably lies at a proportion of > 15 % of the dry mass. Such a soil as an intended substructure for a road would be greatly endangered by influences of frost and water and thus would be unsuitable.

25

For this reason, first in method step b, a first application of the soil-stabilising means 3 onto the supplied soil spread out for processing is carried out and in method step c, the soil is milled and mixed.

30

In method step d, a second application of soil-stabilising means 3 is effected with subsequent repeated thorough mixing in method step e, and the thus homogenised soil for a later stabilising layer 5 is stored until further processing in a protected atmosphere, which is provided, for example with a covering 27 as protection from precipitation and moisture. Hence, a soil prepared for incorporation as a stabilising

layer 5 with optimum water content for compacting, is held for example in a warehouse, which may then be used if required to build up a road. This is effected in method step f, where layer-wise incorporation of the stabilising layer 5 onto a subsoil 28 takes place according to method step e.

5

The packing height of incorporation corresponds to the effective depth of the compactor 7 used in method step g. It is assumed that the compactor 7 has such an effective depth that compacting of the stabilising layer 5 in method step g is also effected into the subsoil 28.

10

Finally, in method step h, a levelling layer 8 is applied to the thus homogenised stabilising layer 5, which has been compacted, and in method step i, the third application of soil-stabilising means 3 onto the levelling layer 8 is effected.

15

Finally, in method step j, compacting is carried out and in method step k, a conventional upper bound sub-base layer 34 and a cover layer 10 comprising asphalt or concrete may be applied to the thus compacted structure 5, 8.

Figure 8 shows the construction and the building sequence for producing a substructure of the invention with the soil-stabilising means 3 of the invention. A levelling layer 8 is arranged below a cover layer 10 and upper bound sub-base layer 34, and the resulting soil of the subsoil, which has been impregnated several times with the soil-stabilising means 3 and thoroughly mixed and thus has been converted to a stabilising layer 5, is stored on an subsoil 1 which is present at the building site.

25

This subsoil 1 may consist of naturally stored loose rock and is usually frost-sensitive. Due to the measures of the invention, this existing subsoil 1 is converted into an impregnated stabilising layer 5 from the existing surface up to the working depth of the miller and is thus high load-bearing and protected against influence of frost and water.

30

It is shown schematically that in method step (1), topsoil removal takes place, in method step (2), loosening of the subsoil and comminution and mixing with a soil miller takes place.

In method step (3), the coarse ground surface is produced, and in method step (4), a mixture of water and the soil-stabilising means 3 (SSM) of the invention is introduced according to the instruction of the manufacturer and intensively mixed with the soil. Soil millers are thus preferably used. The introduction of the soil-stabilising means may take place several times according to method steps (4a) and (4b), wherein preferably at least two working steps take place.

Hence, according to method step (4), a completely homogenised stabilising layer 5 prepared for compacting is present.

10

In method step (5), a fine ground surface is produced on the surface of this layer.

In method step (6), it is monitored whether this soil layer provided as stabilising layer 5 has the optimum water content to subsequently guarantee optimum compacting.

15 If the current water content is higher than the required optimum water content for compacting, the soil must be dried.

If the current water content is less than the required optimum water content for compacting, the soil should be moistened.

20 In method step (7), compacting, preferably using a roller (compactor 7), is effected, wherein this compactor should preferably have more than 15 tonnes of dead weight. This ensures intensive compacting of the stabilising layer 5.

In method step (8), a levelling layer 8 is incorporated.

25

Finally, in method step (9), the upper bound sub-base layer 34, for example as an asphalt sub-base layer, and subsequently in method step (10), the cover layer 10, for example as an asphalt cover layer, is incorporated, and the road is thus produced by the working steps described above.

30 Compared thereto, Figure 9 shows a traditional building sequence and a construction of a traditional road.

It can be seen first from the figure that a traditional road according to the state of the art consists of a cover layer and two sub-base layers lying underneath, namely

an upper bound sub-base layer (usbl) and a lower non-bound sub-base layer (lsbl), wherein the lower sub-base layer is preferably formed as a frost- proofing layer.

5 The existing subsoil 1, which loses its load-bearing capacity under the influence of water and frost, must be removed in the traditional building sequence and replaced with frost-proof rock mixtures without fine proportions to be supplied. This already produces the considerably greater working effort in the production of a road substructure according to the state of the art,

10 Furthermore, it can be seen from Figure 9 that the existing subsoil is optionally subjected several times to soil stabilisation, combined with the incorporation of geotextile and/or geolattice to increase load-bearing capacity.

Method steps (1) to (11) show the production of the road structure according to
15 Figure 9 according to the state of the art.

The higher effort with respect to the method according to Figure 8 lies in the fact that an improvement of the subsoil using traditional stabilising methods must take place (for example lime stabilising or cement stabilising, that additional components
20 (geotextile, geolattice) are necessary, but above all: that frost-endangered soil of the subsoil with poor load-bearing has to be dug out and transported away and hence replaced with expensive frost-proof rock mixtures to be supplied which have to be incorporated as a lower sub-base layer, levelled off and compacted.

25 Finally, only in method step (10), the incorporation of an upper bound sub-base layer 34, for example as an asphalt sub-base layer, and in method step (11), the incorporation of a cover layer 10, for example as an asphalt cover layer, may then be effected.

30 The comparison of the method sequence according to Figure 9 with the method sequence according to Figure 8 shows the advantages of the present invention. The present invention dispenses with the multi-layer structure of a substructure due to supplied frost-proof rock mixtures as a replacement for soil of the subsoil to be cleared away, because a homogeneous stabilising layer is produced with the

repeated introduction of soil-stabilising means into the existing subsoil and due to repeated thorough mixing and subsequent compacting, and therefore a multi-layer structure according to Figure 9 (state of the art) may be dispensed with.

5

Drawing legend

	1	existing subsoil
	2	layer depth 2'
	3	soil-stabilising means SSM
10	4	arrow direction
	5	stabilising layer
	6	arrow direction
	7	compacting equipment
	8	levelling layer
15	9	loam layer
	10	cover layer, for example asphalt cover layer
	11	lower non-bound sub-base layer
	12	stones
	13	layer depth
20	14	scarifier
	15	arrow direction
	16	tendril layer
	17	arrow direction
	18	arrow direction
25	19	sieve
	20	fines
	21	arrow direction
	22	fines 20 treated with soil-stabilising means 3
	23	build-up layer
30	24	recycling material
	25	substructure
	26	subsoil
	27	covering
	28	subsoil

- 29 supplied soil
- 30 supplied soil mixed with SSM
- 31 surface of the ground surface of the existing subsoil
- 32 surface of the cover layer
- 5 33 surface of the sub-base layer stabilised with SSM
- 34 upper bound sub-base layer, for example asphalt sub-base layer

Europeisk patent nr.
EP3134581

NORWAY
P17307NOEP

Søker: Terje Mikkelsen
Dybwadsgate 3
0367 Oslo

Fullmektig: ACAPO AS
Strandgaten 198
5004 Bergen

Oppfinner: Terje Mikkelsen

Prioritet DE20141004936

Tittel: FREMGANGSMÅTE OG JORDSTABILISERENDE
MIDDEL

Patentkrav

1. Fremgangsmåte for permanent jordstabilisering av frostutsatt fin- og blandingskornet mineraljord som høyt bæredyktige og frostsikre fundamentsjikt, bærelag, underlag og fyllag i bygningskonstruksjoner, i veibygging og gateanlegg og i jord- og anleggsarbeid, hvor for å fremstille et eller flere stabilt holdbare, frostsikre og høyt bæredyktige konstruksjonslag (5, 8) til et fundament (1) blandes et flytende jordstabiliseringsmiddel (3) grundig med minst et lag av fundamentet (1) og komprimeres deretter, **karakterisert ved** at som jordstabiliseringsmiddel (3) utelukkende anvendes en vandig blanding av forskjellige sulfonsyrer, som har som felles trekk den funksjonelle gruppen $-SO_3H$, som er forbundet med en vannavvisende organisk bestanddel R med tilsvarende formel $R-SO_3-H$.
2. Fremgangsmåte ifølge krav 1, **karakterisert ved** de følgende trinnene:
- (1) fjerning av matjord (vegetasjonslag) dersom tilstede
 - (2) løsgjøring, oppdeling i småbiter, og blanding av undergrunn
 - (3) framstilling av grovplanum
 - (4) tilsetning av en blanding av vann og jordstabiliseringsmiddel (3) og blanding med jorda
 - (5) framstilling av finplanum
 - (6) kontrollering av vanninnholdet som kreves for komprimeringen
 - (7) komprimering med tungt komprimeringsutstyr (7)
 - (8) installering av et avrettingslag
 - (9) komprimering med tungt komprimeringsutstyr (7)
 - (10) installering av et dekklag (10).
3. Fremgangsmåte ifølge krav 2, **karakterisert ved** at stabiliseringslaget (5) etter framstilling i prosesstrinn (4) blandes godt, og at det deretter utføres en andre innblanding og gjennomfukning av stabiliseringslaget (5) med jordstabiliseringsmiddelet (3).
4. Fremgangsmåte ifølge krav 3, **karakterisert ved** at etter den andre tilsetningen av jordstabiliseringsmiddelet (3) i jorden, blir det således fremstilte stabiliseringslaget (5) komprimert, deretter påføres et øvre utjevningsslag (8) etterfulgt av en tredje gjennomfukning med jordstabiliseringsmiddelet (3) på overflatesiden av stabiliseringslaget (5).

5. Fremgangsmåte ifølge krav 4, **karakterisert ved** at som avsluttende arbeidstrinn for fremstilling av planumet, komprimeres avretningslaget (8) sammen med det underliggende stabiliseringslaget (5) som er gjennomfuktet flere ganger.
- 5 6. Fremgangsmåte ifølge ett av kravene 1 til 5, **karakterisert ved**, at ved det tilfellet at jorda som skal stabiliseres har for få finkornede materialer, påføres et jordlag med høyere andel av finkornet material som et første lag på fundamentet (1), for eksempel av leire og/eller slam og/eller silt og/eller leiret løsstein og/eller filteraske.
- 10 7. Jordstabiliseringsmiddel for permanent jordstabilisering av frostutsatt fin- og blandingskornet mineraljord som høyt bæredyktige og frostsikre fundamentsjikt, bærelag, underlag og fyllag i bygningskonstruksjoner, i veibygging og gateanlegg og i jord- og anleggsarbeid, **karakterisert ved** at jordstabiliseringsmiddelet (3)
- 15 utelukkende består av en vandig blanding av forskjellige sulfonsyrer, som har som felles trekk den funksjonelle gruppen $-SO_3H$, som er forbundet med en vannavvisende organisk bestanddel R med tilsvarende formel $R-SO_3-H$.
8. Jordstabiliseringsmiddel ifølge krav 7, **karakterisert ved** at
- 20 jordstabiliseringsmiddelet (3) forårsaker at hydrogenionene H^+ adhesivt bundet til overflaten av jordpartiklene (og dermed det ytterligere vannet festet til disse ionene via hydrogenbindinger) fortreges av (+) metallioner, for eksempel Na^+ , K^+ , Mg^{++} , Ca^{++} , Al^{+++} , som er tilstede i vannskallet.
- 25 9. Jordstabiliseringsmiddel ifølge ett av kravene 7 eller 8, **karakterisert ved** at med jordstabiliseringsmiddelet (3) fortreges en stor del av det fastbundne adhesjonsvannet fra overflaten til jordpartiklene og dannes om til fritt porevann.
10. Jordstabiliseringsmiddel ifølge ett av kravene 7 til 9, **karakterisert ved** at (+)-
- 30 metall-ionene som er forbundet med jordpartiklene ikke lenger binder hydratvann når jordstabiliseringsmiddelet (3) anvendes, idet syre-rest-ioner i jordstabiliseringsmiddelet (3) forbindes med metall-ionene, slik at absorpsjonsvannskallet reduseres gjennom en utskiftingsmekanisme.
- 35 11. Jordstabiliseringsmiddel ifølge ett av kravene 7 til 10, **karakterisert ved** at syre-rest-ionene (sulfatgruppe), tilstede i jordstabiliseringsmiddelet (3) og festet på metall-ionene, er forbundet med en hydrofob organisk del.

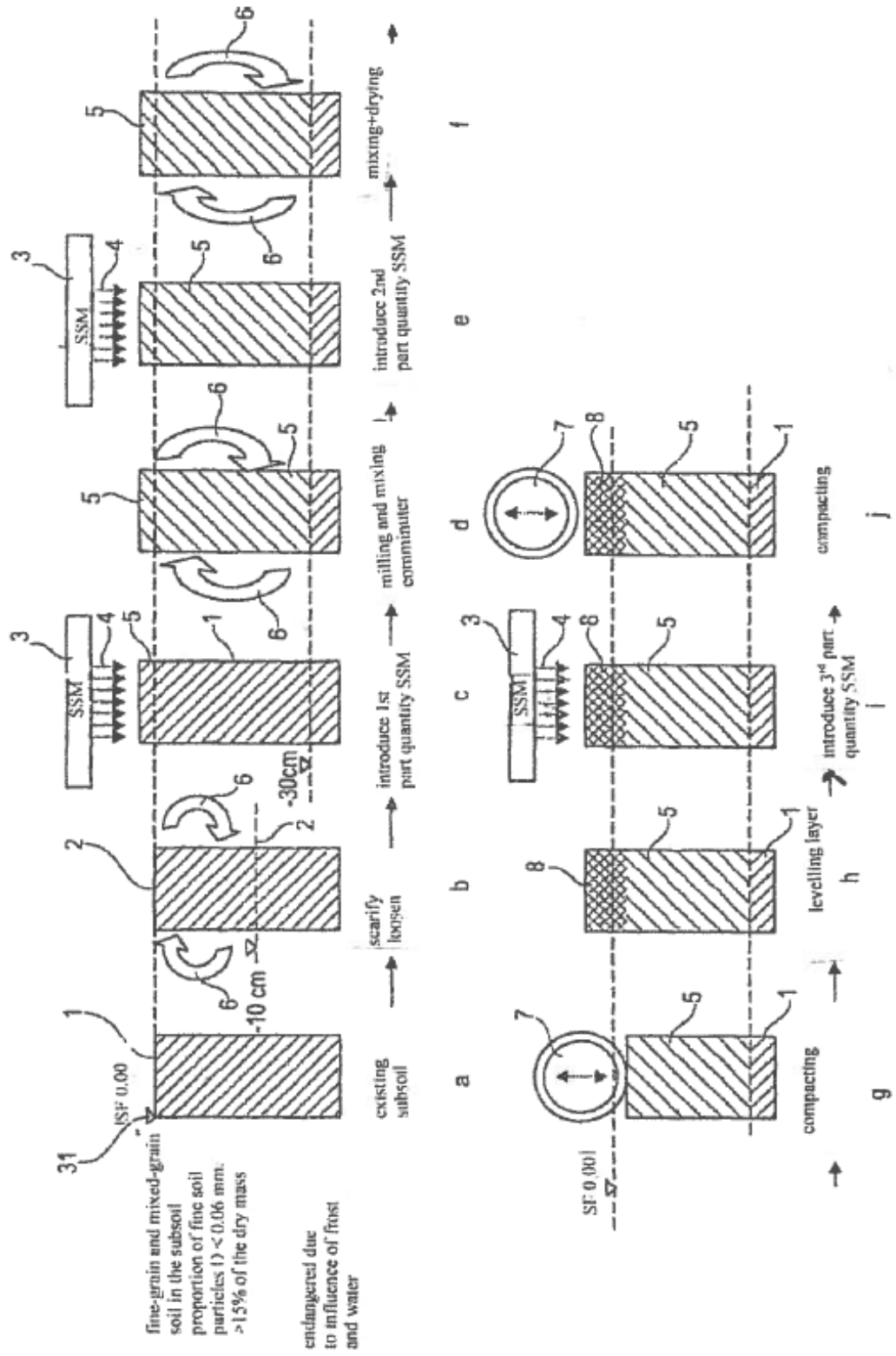
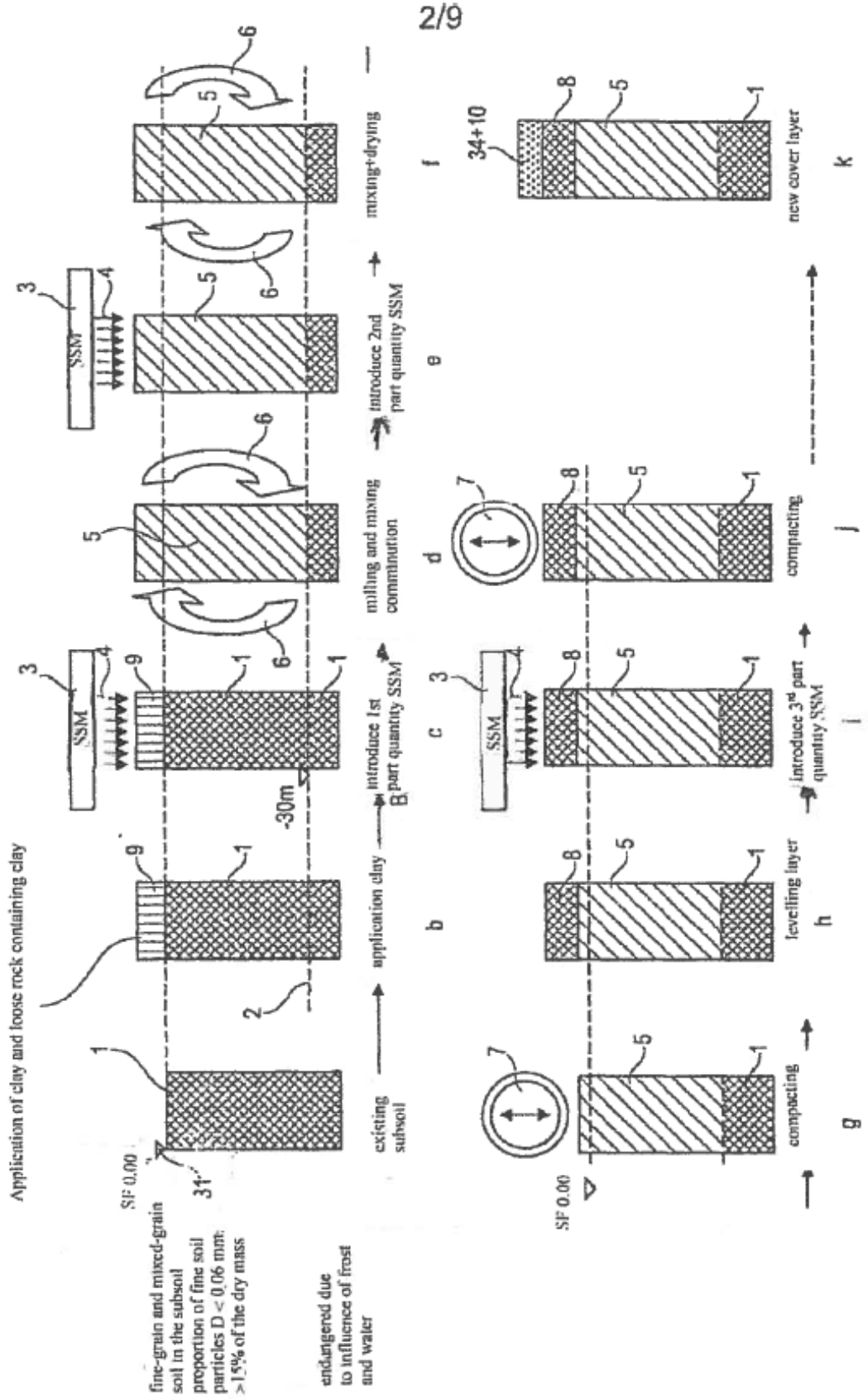

Fig. 1



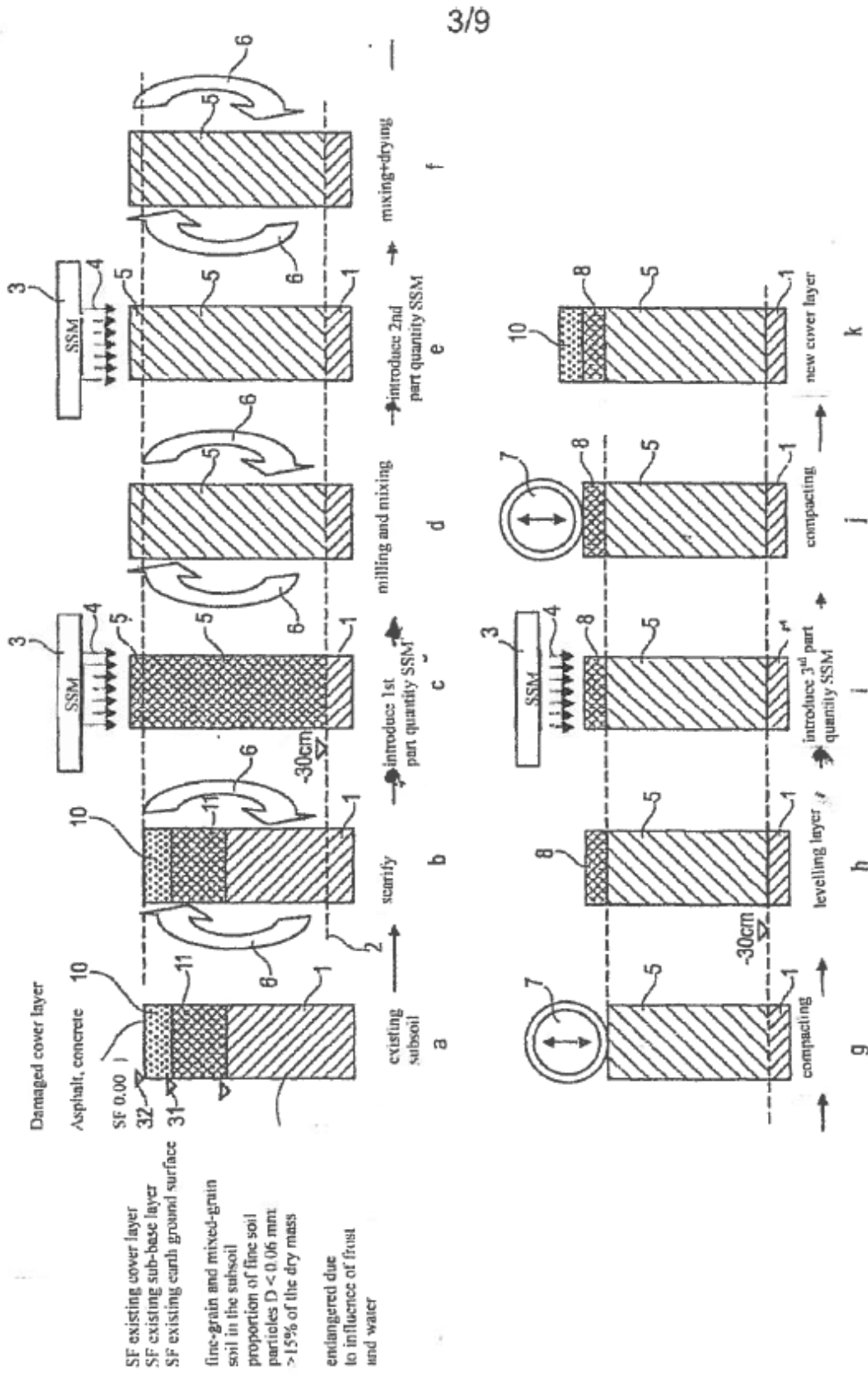

Fig. 3

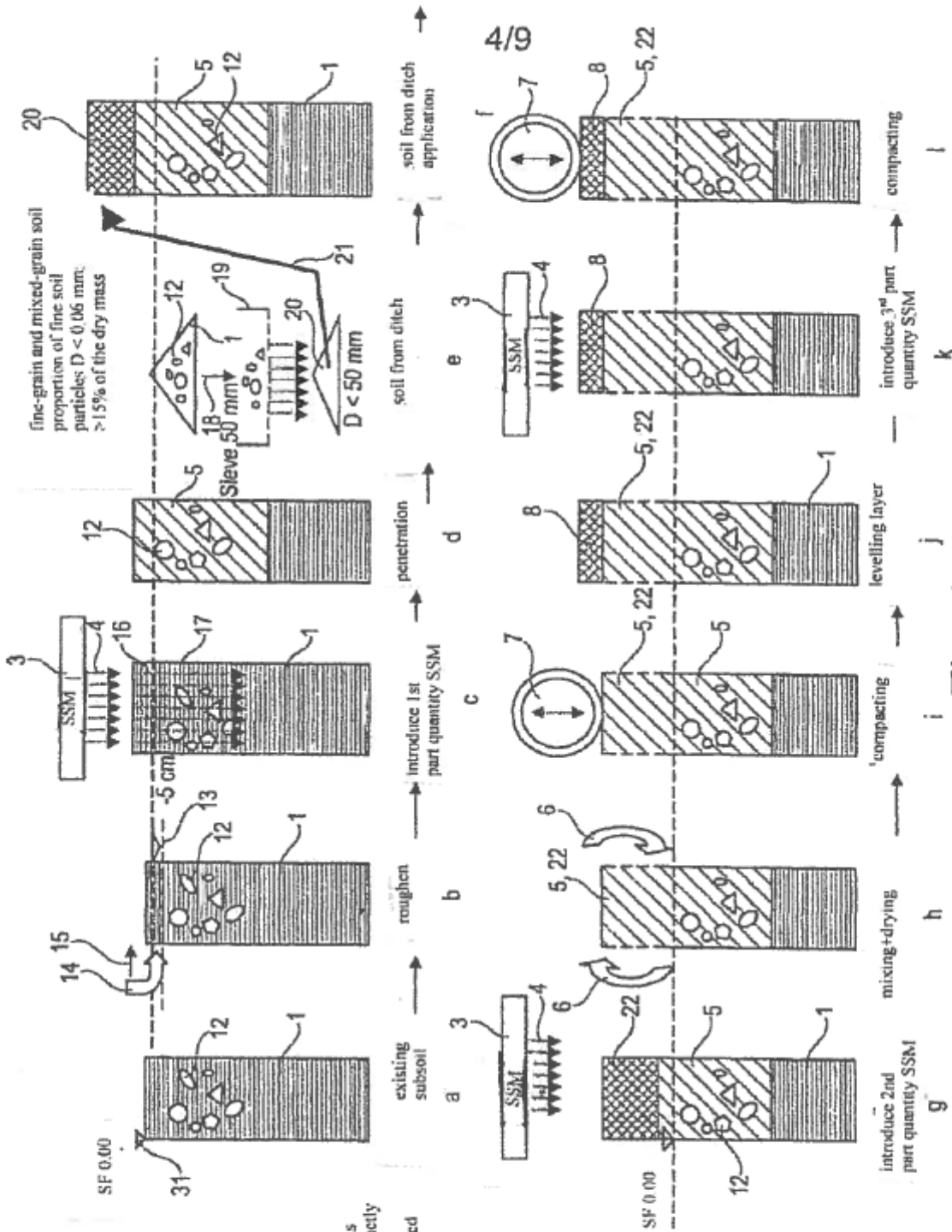
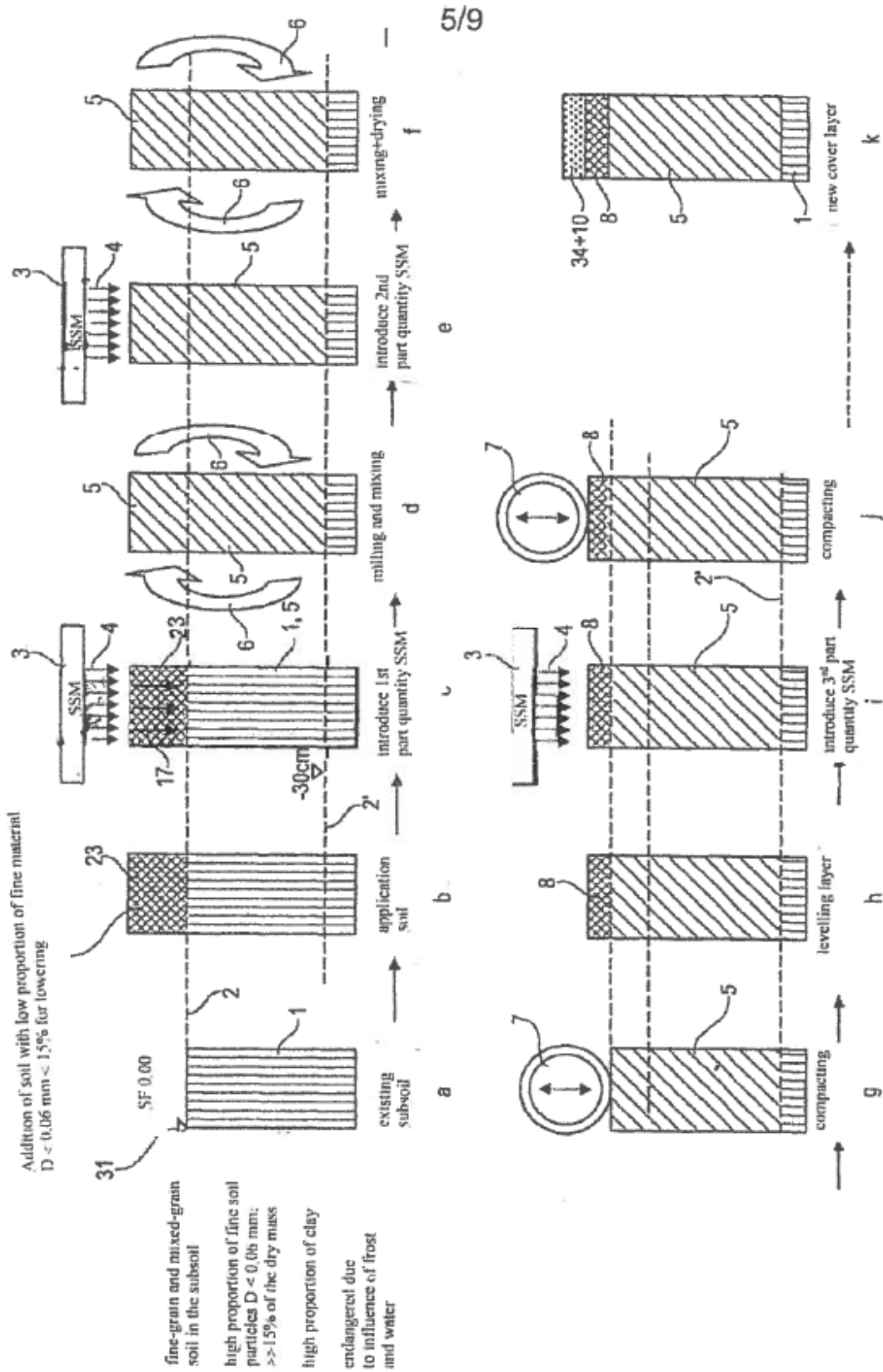

Fig. 4



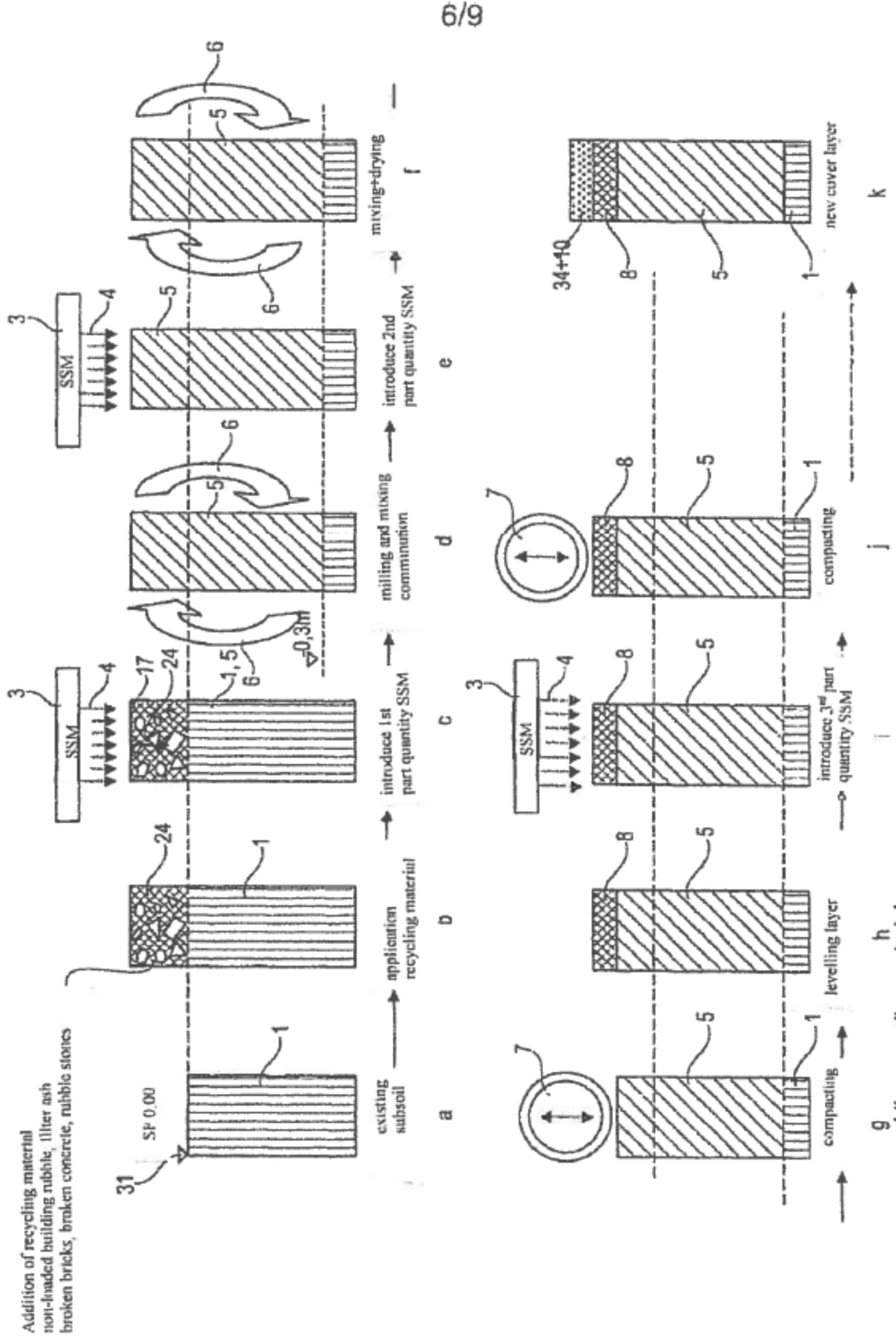

Fig. 6

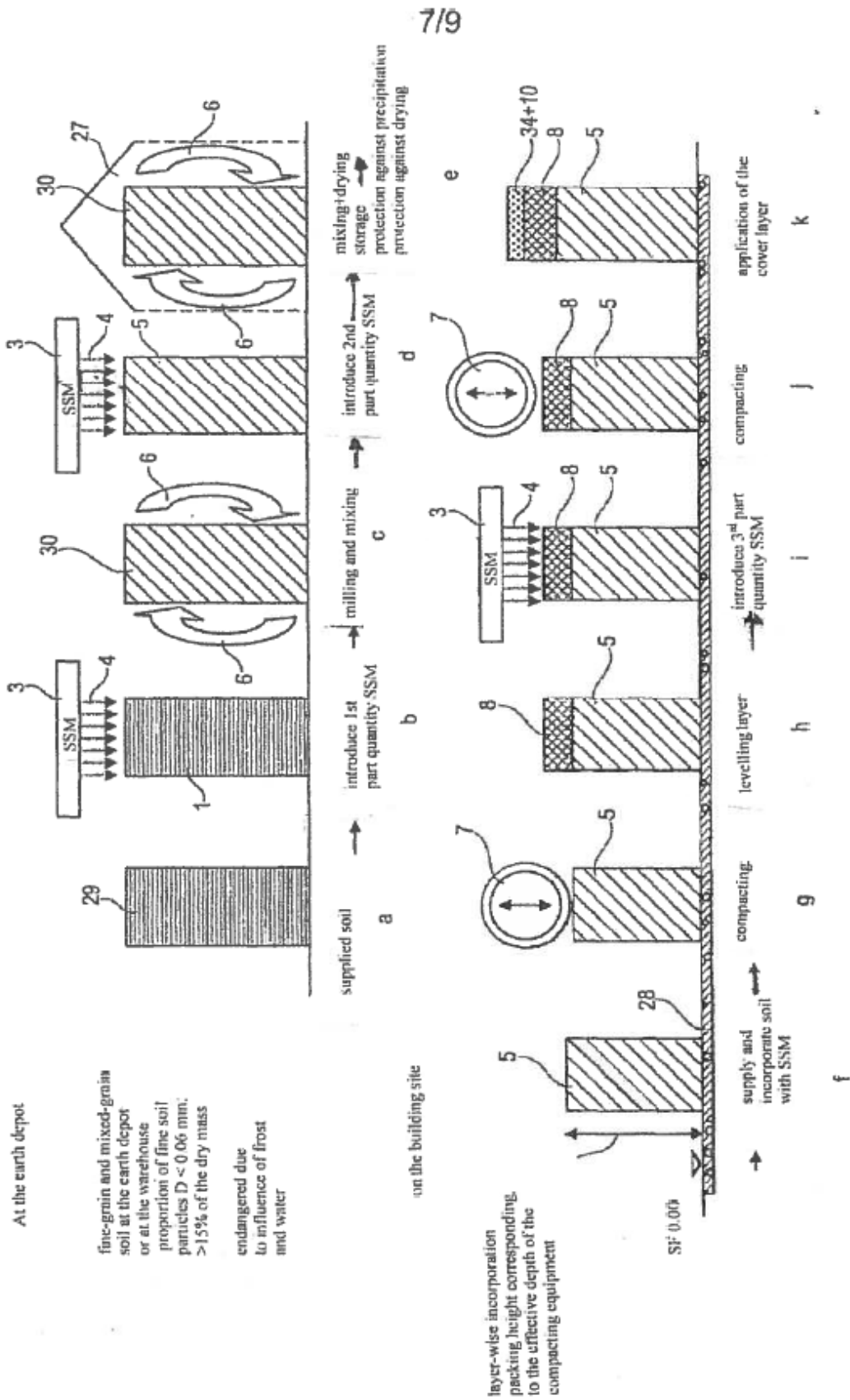

Fig. 7

8/9

Construction and building sequence with GF:

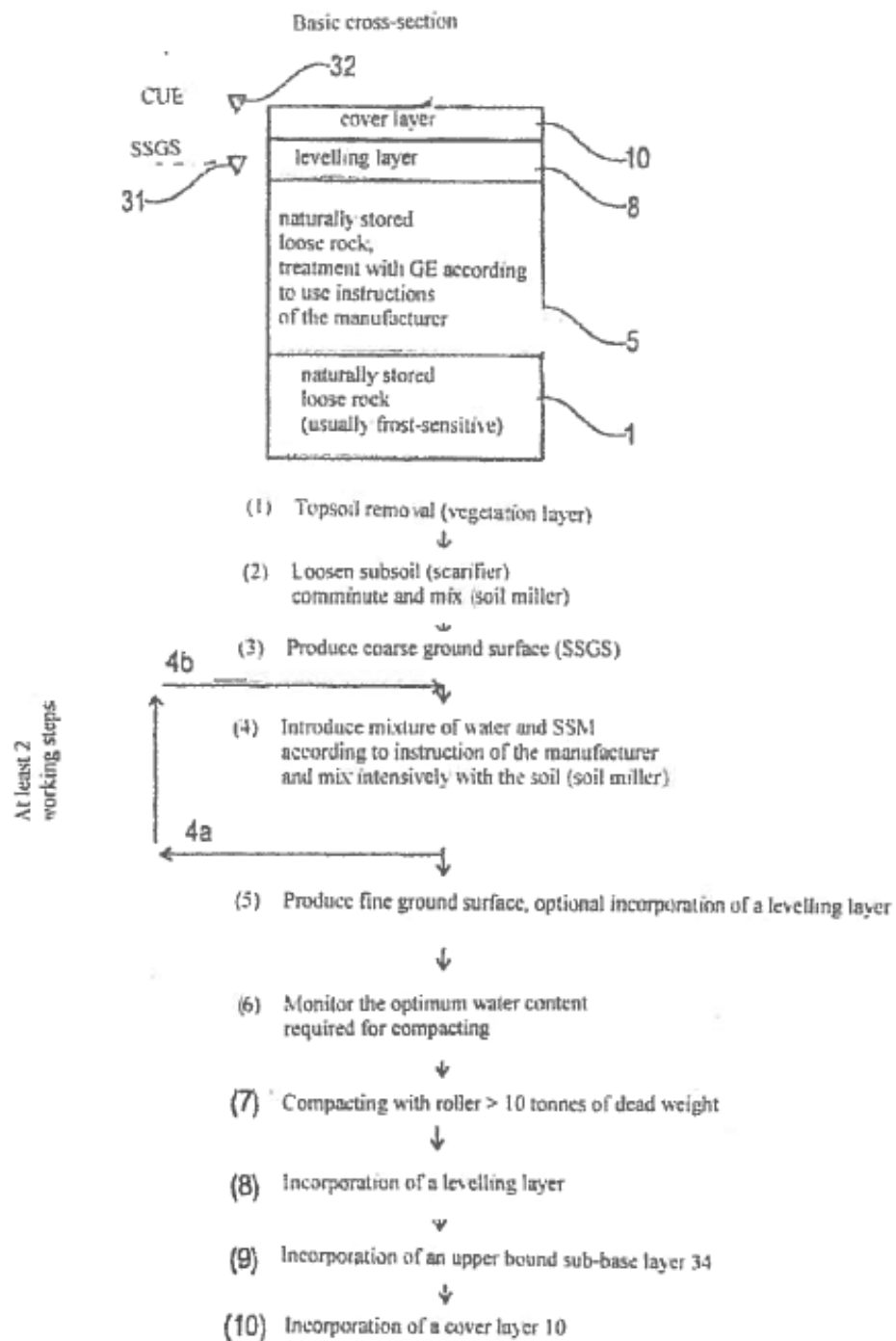

Fig. 8

Example: Road building in excavation, subsoil: cohesive loose rock (usually frost-sensitive)
 traditional construction and building sequence

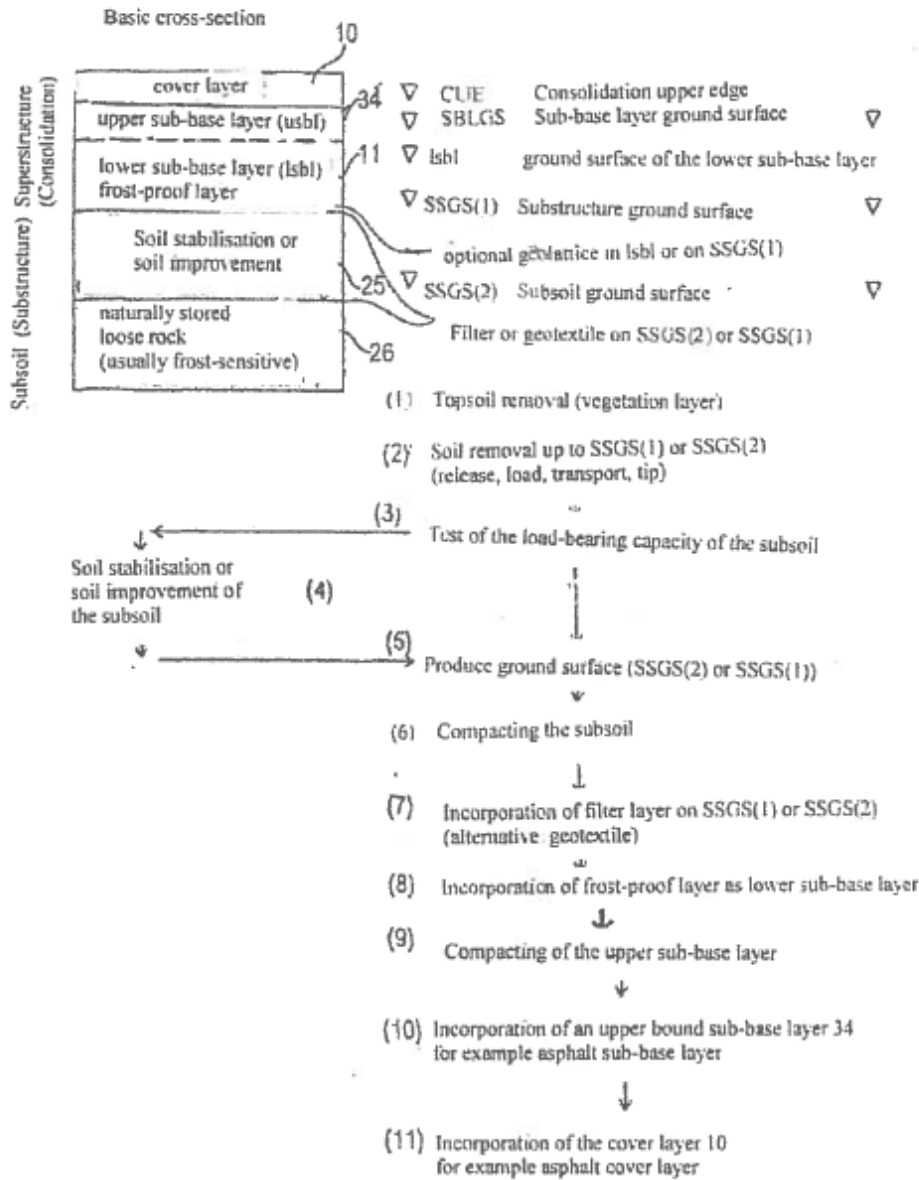

Fig. 9
 (State of art)