



(12) **Oversettelse av
europeisk patentskrift**

(11) **NO/EP 2795133 B1**

NORGE

(19) NO
(51) Int Cl.

F04D 15/00 (2006.01)
F24D 3/10 (2006.01)
F24D 11/00 (2006.01)
F24D 19/10 (2006.01)

Patentstyret

- (21) Oversettelse publisert 2016.06.06
- (80) Dato for Den Europeiske Patentmyndighets publisering av det meddelte patentet 2016.04.06
- (86) Europeisk søknadsnr 12822971.3
- (86) Europeisk innleveringsdag 2012.12.21
- (87) Den europeiske søknadens Publiseringsdato 2014.10.29
- (30) Prioritet 2011.12.22, DE, 102011056866
- (84) Utpekte stater AL AT BE BG CH CY CZ DE DK EE ES FI FR GB GR HR HU IE IS IT LI LT LU LV MC MK MT NL NO PL PT RO RS SE SI SK SM TR
- (73) Innehaver AZ - Pokorny Trade S.r.o., Cermakovice 20, 671 73 Tulesice, CZ-Den tsjekkiske republikk
- (72) Oppfinner CHYTIL, Lubor, Planava 214, 742 66 Stramberk, CZ-Den tsjekkiske republikk
- (74) Fullmektig Protector Intellectual Property Consultants AS, Oscarsgate 20, 0352 OSLO, Norge

(54) **Benevnelse** **ARRANGEMENT WITH STORAGE ELEMENT AND HEAT SUPPLY SYSTEM**

(56) **Anførte publikasjoner** EP-A1- 2 360 442
DE-A1- 4 409 883
DE-A1- 19 706 067
DE-U1- 9 205 301
JP-A- S5 828 933

- 1 -

Description

The invention relates to an arrangement with a storage element and a heat supply system.

5

It is known that heat generators, such as heating boilers, have to be scaled with a higher heat output than the predicted overall heat demand in the corresponding heat supply system. This is because the heat generator in such heat supply systems must always be designed according to the maximum required heat demand.

10

If a heat supply system scaled according to this design rule is operated with a solid fuel boiler, difficulties with the heat balancing inside such a system result therefrom.

15 According to a proposal in CH 342 354, there should therefore be assigned to such a heat supply system a heat storage element which is connected in parallel to the existing heat consumers (heating elements). The incorporation into the heat supply system takes place in each case by means of a three-way valve in the flow line and return flow line of the heat supply system and by means of forced circulation with a thermostat-controlled circulating pump in the consumer circuit of the
20 heat supply system.

Depending on the position of the three-way valves, either the consumer circuit, the heat storage element or both can be put into operation.

25

In the case of operation of the consumer circuit together with the heat storage element, an operating regime emerges which extracts the required liquid quantities virtually optionally either from the solid fuel boiler or the heat storage element or both. A hydraulic compensation is not provided. The proposed system can thus
30 only be operated expediently in a way such that the hot water storage tank is directly charged by the solid fuel boiler with a corresponding valve setting, wherein the consumer circuit and the circulating pump are switched off with such in a

- 2 -

switching variant. The pump-free circulation thus arising lengthens the charging intervals.

The main drawback with this heat supply system therefore consists in the fact that
5 a hydraulic compensation and charging of the heat storage element with a pressure flow are not possible.

In particular, an excess supply of heat quantities can also occur due to the fact that further heat sources, such as for example thermal solar collectors, are connected to such a heat supply system. In particular, considerable disparities arise
10 between the supply of heat quantities and the take-off thereof. In addition, there is the fact that the timing between the heat generation and heat consumption is not coincident.

15 To find a remedy for this, storage elements are present in heat supply systems, said storage elements offering the possibility, when there is a temporary oversupply of heat quantities, of being able to temporarily store these heat quantities and to retrieve them again later. In order to enable this, heated medium has to be pumped in the direction of the storage element when there is an excess supply.
20 When there is an undercovered demand, the same medium has to be pumped in the reverse direction from the storage element back into the heating circuit.

On account of the useful life of circulating pumps being reduced with high media temperatures, the latter have for some time only been incorporated in the line section that always has the lower temperature. This requires that two different flow
25 directions are required for charging and discharging the heat storage element.

These tasks cannot be performed with a circulating pump, which is usually a centrifugal pump or can only operate in one delivery direction. Heat supply systems
30 have therefore already been designed, wherein two pumps with in each case opposite delivery directions are connected in parallel in the line circuit between the heat source and the heat storage element. However, shut-off valves have to be

- 3 -

assigned to said pumps if the medium is always to be delivered only in one specific direction.

It is also known to dispose an electrically controlled two-way servo-valve in each
5 pump branch in such pump arrangements connected in parallel, in order in this way to avoid a short circuit of the media flow via the pump that is at a standstill at the time.

Such arrangements are expensive, especially since they require still further control
10 devices, which on the one hand open and close the line paths and on the other hand control the two pumps.

An arrangement with two pumps connected in series is proposed in DE 44 09 883
C2, said pumps each being connected with their suction sides to the return flow
15 line of a heat consumer. In this arrangement, a media flow can be connected in the return flow line of a heat consumer to a pump with a heat generator (heating boiler) or to another pump with a heat storage element. In order to avoid feed-backs, a non-return valve is proposed in each case in the return flow line of the heat consumer and in the flow line of the heat generator.

20

The system is disadvantageous, inasmuch as the same arrangement of pumps and non-return valves again has to be provided in the case of further heat sources being assigned and also when a plurality of line circuits to heat consumers are provided. The cost with more complex systems thus increases very sharply.

25

It is proposed in JP S58 28933 A to operate a circulating pump located downstream of a heat source in the flow line by means of a downstream 4/2 valve, in such a way that a specific number of heating elements is supplied with heated medium, on the one hand starting from the first heating element and on the other
30 hand, after switching over the 4/2 path valve, from the last heating element. The purpose of this arrangement is to be able to mutually interchange the flow line and flow return line of a heat supply system and thus to ensure uniform heating of all the heating elements. A broader proposal makes provision such that the corre-

- 4 -

sponding switch-over is carried out automatically at fixed time intervals. A further proposal makes provision such that, when an upper limiting temperature in the heating elements is reached, a control signal is delivered to the control device by means of a heat sensor, said control signal then interrupting the supply to the
5 heating elements.

The arrangement described above is used exclusively for switching over from the flow line to the return flow line in a conventional heating circuit, in order to achieve uniform heating of all the heating elements present in the circuit. The described
10 arrangement is not suitable for a reversal of the flow direction in a supply line of an additional heat supply element.

An arrangement is known from EP 1 906 101 A1 which connects two pumps in each case with the pressure side in a line, so that a specific flow direction is forced
15 by switching on one of these pumps each time. The media flow flows through the pump that is out of operation at the time.

A comparable arrangement is known from a Eco Zenith I 555 heat supply system from the company CTC AB, 34126 Ljungby, Sweden. In this system, additional
20 non-return valves are disposed between the two pumps connected with the pressure sides.

Despite the simplified design, this arrangement has the drawback that the pump that is out of operation at the time represents a considerable line resistance, which
25 forces an increase in the pump output. Furthermore, it cannot be ruled out that a correspondingly large media flow will cause corrosion and cavitation damage during the flow around the impeller of the stationary pump. These drawbacks are further exacerbated if a flow also takes place through non-return valves, in addition to the pump.

30

Apart from the drawbacks indicated with the individual solutions existing in the prior art, there are further drawbacks. Systems which operate with two pumps inde-

- 5 -

pendent of one another thus require a separate control, as a result of which the control outlay in such heat supply systems increases.

If combinations with two circulating pumps are additionally equipped with controlled valves, the control outlay increases still further.

Moreover, the synchronisation is lacking with the individual components of the systems existing in the prior art. Controlled valves or pumps generate knocking in the line circuits. The hydraulic compensation is absent in many solutions.

10

In systems which place special emphasis on obtaining renewable energy with the aid of solar-thermal heat sources, the systems known from the prior art cannot meet the requirements for a maximum energy gain from these sources. To do this, it is necessary to integrate a secondary heat storage element for the balancing of the heat quantities inside a heat supply system, in such a way that said secondary heat storage element can supply heat quantities into the consumer circuit and remove them from the generator circuit as required and inertia-free. The combination storage elements with a large heat quantity buffer also known in the prior art and integrated as a heat sink into heating circuits cannot meet the requirements. They are too sluggish in their behaviour. On the other hand, a heat sink with a lower inertia requires a rapid reaction by a secondary hot water storage tank, in order to compensate approximately the supply or lack of heat quantities with respect to the heating circuit of a heat supply system. This cannot be achieved with the pump arrangements known from the prior.

25

It is the problem of the invention, therefore, to propose an arrangement which can handle the tasks of charging and discharging at least one heat storage element in heat supply systems with a low cost, installation and control outlay, which operates in the optimum manner in terms of energy and cost, avoids pressure surges, enables a hydraulic compensation and can be adapted in diverse ways with regard to its integration into existing systems.

30

This problem set out above is solved with an arrangement with the features of the characterising part of claim 1 in combination with the features of the preamble of this claim. Coordinated claims and sub-claims describe embodiments of the arrangement according to the invention.

5

In the following description, the examples of embodiment and the claims, the terms listed below are used with the following meanings:

Heat supply system — is an arrangement which comprises at least one heat generator, a heat consumer and a heat storage element chargeable and dischargeable by means of a pump.

Pump arrangement — is an assembly of at least one pump having an arbitrary design, line segments and valves for solving the problem, with a pump unit for charging and discharging the storage element.

Storage element — is a volume storage element of any size and design, which can be charged and again discharged with a medium transporting heat quantities.

Backflow preventer — is a component or a subassembly which is suitable for allowing the media flow of the pump to pass for the most part unhindered, but is suitable for closing the line section in the case of a sustained or pulsed counterflow in the pump line.

Controllable — means that the pump arrangement can be put into operation and be brought to a standstill on the basis of arbitrary decisions and interventions into the heat supply system.

Regulatable — means that the pump is put into operation or brought to a standstill depending on measured values detected in the system, processed control variables or on the basis of processing routines of a higher-level control system. Such kinds of control systems can be integrated into the pump arrangement or can be constituted as a central control system of the heat supply system.

- 7 -

According to the invention, it is assumed that a further optimisation of the use of thermal energy in heat supply systems can be achieved by the fact that a storage element additionally disposed in such a system is charged or discharged with only one pump with low inertia. The previously used arrangements with two pumps thus
5 become unnecessary.

The invention in particular takes account of those heat supply systems that are equipped with heat generators, by means of which heat quantities are obtained from renewable energies and in which a so-called heat sink performs the task of
10 making available heat quantities for the heating circuit. However, the arrangement according to the invention can also be used in conventional heat supply systems, if a secondary heat storage element is additionally provided in the latter.

Additional resistances due to a second pump, through which a flow must take
15 place, cease to be present, and likewise the installation and maintenance costs for a second pump. Furthermore, possible damage due to cavitation, corrosion and ageing is avoided with the pumps respectively put out of operation.

According to the invention, the arrangement is constituted such that a mutual con-
20 nection to the supplying and discharging line parts is enabled with the aid of valves or stopcocks and the delivery direction of the pump can thus be switched within shorter intervals. According to the invention, this has the advantage that only actuating pulses with low energy consumption are required for actuating the valves or stopcocks, whilst the pump can deliver media in the optimum operation even after
25 the switch-over.

In order to be able to operate the pump in the optimum manner from the energy standpoint, the latter is controlled in a power-optimised manner. This means that the quantity of energy is always made available to the pump that is necessary to
30 maintain the required parameters.

Particular preference is given to a control of the energy quantities of the circulating pump by controlling the pump drive motor by means of a pulse width control,

- 8 -

which is actuated by analog signals and which, on the basis thereof, ascertains the energy quantities for the operation of the circulating pump.

The acquisition of analog signals by the arrangement of a temperature sensor at a
5 point in the consumer circuit of the heat supply system is particularly advantageous, which advantageously comes into question for the ascertainment of a set-point temperature. The charging or discharging of the connected heat storage element can thus be controlled almost free from inertia and the maintenance of the thermo-technical requirements can thus be ensured in a straightforward manner.

10

Such a control of the circulating pump can be constituted in parallel with a control for the heat supply system or can be integrated into the latter.

A control of the energy quantities by means of a so-called pulse width control is
15 preferred, since the latter can be carried out with low-cost components and control or regulating units.

A pulse width control with the aid of a so-called switching controller or a so-called controllable pulse modulation unit in the form of an electronic component is particularly
20 preferred.

The use of an electronic component of the family SG3524 is again particularly preferred here, because the latter can be controlled by an analog control signal. The prerequisite is thus provided for connecting an analog temperature sensor directly
25 to the control unit of the circulating pump.

Such a control can of course also be controlled by an analog output of a central control system of the heat supply system.

30 In cases in which longer line paths to the storage element occur within the heat supply systems or increased feed pressures through the storage element are required, a multistage pump or a pump cascade can be used, wherein the control can take place as described above.

- 9 -

The switch-over unit required inside the pump arrangement is constituted with a 4/2 valve in the preferred case. In one switching position, the latter connects the suction side of the pump to the heat generator and the pressure side of the pump to the storage element. In the second switching position, the suction side of the
5 pump is connected to the storage element and the pressure side is connected by the line to the heat generator.

A so-called ball valve, which has the at least two required switching positions and can be actuated with auxiliary energy, is particularly preferred for the 4/2 valve.

10

Instead of a 4/2 valve, use can be made of two 3/2 valves, four 2/2 valves or also arrangements with ball valves.

In order to protect the heat supply system and the pump, a backflow preventer is
15 connected upstream or downstream of the latter. An arrangement downstream of the pressure-side connection of the pump is preferred here.

The pump arrangement can be constituted, depending on the embodiment of the heat supply system, in construction units with interconnected line segments or as
20 a pump arrangement in a compact design or as a pump arrangement in a block design.

The invention is explained below in greater detail with the aid of several examples
25 of embodiment and drawings. In the figures:

Fig. 1 — shows a diagrammatic representation of a heat supply system with a storage element disposed in the latter.

30 Fig. 2 — shows a diagrammatic representation of the pump arrangement according to the invention using a 4/2 valve in a switching position in which a pump is delivering a media flow in the direction of a heat source.

- 10 -

Fig. 3 — shows the diagrammatic representation shown in fig. 2 with a switching position of the directional valve in which the pump is delivering a media flow in the direction towards a connected storage element.

- 5 A heat supply system of the design known per se comprises a heat generator **1**, a heat consumer **2** and lines **3** connecting the latter for the hot region (flow) and **4** for the cold region (return flow).

A heating circulation pump **5** can also be integrated into the heat supply system.

10

Line segments **6** and **7** are led from line **4** to a storage element **8**. Also disposed between line segments **6** and **7** is a pump arrangement **9**, which charges or discharges storage element **8** depending on the requirement.

- 15 Storage element **8** can be connected via connecting line **10** to line **3**, so that medium heated by the storage element **8** can be fed directly into the supply circuit.

The pump arrangement according to the invention in line segments **6** and **7** comprises a pump **11**, a 4/2 valve **12**, a backflow preventer **13** and connecting lines
20 **14**, **15** and **16**.

In fig. 2, 4/2 valve **12** is in a first switching position, which can also be referred to as the 0° position. Switching element **17** then conveys the medium from line segment **7** via line **14** to pump **11**, onward via a line **15**, backflow preventer **13** and
25 line **16** into line **6**. A heat consumer **2** can thus be supplied with heated medium by discharging a storage element not represented in fig. 2.

In the switching position represented in fig. 3, which corresponds to the 90° position, 4/2 valve **12** is switched in such a way that charging of a storage element not
30 represented in fig. 3 is possible. Heated medium is pumped from heat generator **1** into line 7 via line **6**, 4/2 valve **12**, pump **11**, line **15**, backflow preventer **13** and line **16**. The medium discharged from the storage element is pumped via line **10** in the direction towards a heat consumer **2**.

- 11 -

Backflow preventer **13** is disposed on the pressure side of pump **11** and is connected to the latter via line **15**. Backflows in the line circuit are thus prevented, regardless of whether the backflow would occur in a pulse-like manner or in a sustained manner on account of a counter-pressure that has arisen.

5

The way in which the pump arrangement is connected to the heat supply system or the types of connection with which this is achieved is unimportant for the invention. This relates in particular to the feed-in points, at which line segments **6** and line **10** are connected. Whether line **10** is present in the system is equally unimportant for the invention.

10

Pump **11** is preferably a power-controlled pump. Particularly preferred here is a pump control which operates with a pulse width control and always provides pump **11** with the energy quantities which are precisely required to perform the task.

15

The control of pump **11** can be achieved by its own control module or by a central control system of the heat supply system. It is also possible to influence the energy flow to pump **11** by controlling procedures.

20 An analog signal is fed to pump **11**, so that a control module or a central control system can generate a pulse-modulated oscillation therefrom.

The pulse-modulated oscillation is generated by an integrated switching controller or a controlled pulse width modulator, switching circuits of group SG3524 or their derived model preferably being used with the modulator.

25

The control of the module preferably takes place with analog signals in a voltage range between 0 and 10 V. The switching controller or modulator preferably operates at a frequency of 4 kHz.

30

4/2 valve **12** can be replaced by other identically acting valve arrangements at the cost of certain drawbacks. Thus, for example, by an arrangement with two 3/2 valves, by an arrangement with four 2/2 valves or also with an arrangement of a

- 12 -

plurality of ball valves. Ultimately, it is important that an interchange of the suction side and the pressure side of pump **11** with respect to line segments **6** and **7** is brought about.

- 5 Particularly preferred, however, is a 4/2 valve **12** in the embodiment as a ball valve on account of the simple design thereof and the reliable mode of operation.

4/2 valve **12** or the other switching arrangements can also be actuated by control commands and energy supply and do not require any manual operation.

10

Backflow preventer **13** can be constituted in various ways. Thus, it can for example be a device which works with a float or a device which is provided with a swivel-mounted non-return flap. A further embodiment consists in the fact that the closure body is spring-loaded and backflow preventer **13** is accordingly constituted as

15 a non-return valve.

The pump arrangement constituted according to the invention is capable of enabling an effective control of the heating circuit both in cooperation with a heating boiler and in cooperation with a heat sink.

20

In particular, the known fluctuations in the energy provision of solar collectors integrated into the supply systems can be compensated for with the aid of the pump arrangement according to the invention and its control system in that, depending on the heat supply or heat removal, the pump is switched into a delivery direction
25 in such a way that it removes excess heated medium from the heating circuit or feeds excess heated medium to the heating circuit from buffer storage element.

The effect of the simultaneously operating pulse-width modulated energy supply of the pump is that the latter always operates with the optimised volume flow and
30 overshooting of the temperatures in the heating circuit is avoided.

It is possible to dispose a temperature sensor, which delivers an analog measurement signal, at a point of the heating circuit which has been determined as the

- 13 -

optimum, in order thus to bring about an operation of the heating circuit under optimum conditions.

The pump arrangement described above thus has the advantage that it enables in
5 a straightforward manner an operation of the pump in two flow directions and the
expenditure on components and the flow-mechanical design can thereby be opti-
mised. Furthermore, the energy input is minimised by the solution according to the
invention, in such a way that the flow losses are kept low, valve controls are sup-
plied with energy only when necessary and the pump contained in the arrange-
10 ment only receives the energy quantities that are precisely required to perform the
task.

15

20

25

30

List of reference numbers

- 1 heat generator
- 2 heat consumer
- 5 3 line
- 4 line
- 5 heating circulation pump
- 6 line segment
- 7 line segment
- 10 8 storage element
- 9 pump arrangement
- 10 connecting line
- 11 pump
- 12 4/2 valve
- 15 13 backflow preventer
- 14 line
- 15 line
- 16 line
- 17 switching element

20

25

30

P a t e n t k r a v

1.

Arrangement med et lagringselement (8) og et varmetilførselssystem, hvor en varmegenerator (1) er forbundet med en varmeforbruker (2) i en første ledningskrets og en det kan erholdes sirkulasjon av et varmemedium mellom sistnevnte med en varmesirkulasjonspumpe (5), og, med en andre ledningskrets, et lagringselement (8) og et pumpearrangement (8) kan være forbundet med den første ledningskretsen, at det om nødvendig kan erholdes en mediestrøm fra lagringselementet til varmeforbrukeren ved hjelp av pumpearrangementet og at lagringselementet (8) tilveiebragt i den andre ledningskretsen derved kan tømmes,

k a r a k t e r i s e r t v e d at ved hjelp av pumpearrangementet (9) kan det om nødvendig erholdes en mediestrøm fra varmegeneratoren (1) til lagringselementet (9) og lagringselementet tilveiebragt i den andre ledningskretsen kan derved fylles, hvilket pumpearrangement (9) er et arrangement innbefattende en pumpe (11), en omkoblingsanordning og en tilbakestrømsforhindrer og sistnevnte samvirker med lagringselementet (8) på en slik måte at:

- i en første posisjon av omkoblingsenheten, er pumpen (11) forbundet – ved sugesiden – til lagringselementet (8) og ved trykksiden til den første ledningskretsen, hvorved medium med lav temperatur blir matet til sistnevnte fra lagringselementet (8),
- i en andre posisjon av omkoblingsenheten, er pumpen (11) forbundet – ved trykksiden – til lagringselementet (8) og ved sugesiden til den første ledningskretsen, hvorved medium, ved an lav temperatur blir fjernet fra sistnevnte og tilført med pumpen (11) inn i lagringselementet (8).

2.

Arrangement for å operere et lagringselement (8) i et varmetilførselssystem i henhold til krav 1,

k a r a k t e r i s e r t v e d at pumpen (11) er kontrollert eller regulert med hensyn til sin effekt ved hjelp av pulsbreddemodulering (PWM) som en funksjon av størrelsen til analoge inngangssignaler.

3.

Arrangement for å operere et lagringselement (8) i et varmetilførselssystem i henhold til krav 2,

5 k a r a k t e r i s e r t v e d at kontrollen eller reguleringen av pumpen (11) skjer ved å tilføre sistnevnte minst et analogt signal.

4.

Arrangement for å operere et lagringselement (8) i et varmetilførselssystem i henhold til hvilke som helst av kravene 1 til 3,

10 k a r a k t e r i s e r t v e d at pumpen (11) utgjøres av en flertrinns eller som en pumpekaskade med minst en ytterligere pumpe.

5.

Arrangement for å operere et lagringselement (8) i et varmetilførselssystem i henhold til hvilke som helst av kravene 1 til 4,

15 k a r a k t e r i s e r t v e d at omkoblingsenheten er et arrangement som, uten å endre rotasjonsretningen eller tilførselsretningen til pumpen (11), muliggjør omkobling av ledningsforbindelsene iden andre ledningskretsen og minst to tilførselsretninger for mediestrømmen for fylling og
20 tømning av lagringselementet.

6.

Arrangement for å operere et lagringselement (8) i et varmetilførselssystem i henhold til krav 5,

25 k a r a k t e r i s e r t v e d at omkoblingsenheten utgjøres av en 4/2 ventil (12) eller en 4/2 stoppekran.

7.

Arrangement for å operere et lagringselement (8) i et varmetilførselssystem i henhold til krav 6,

30 k a r a k t e r i s e r t v e d at omkoblingsenheten utgjøres av to 3/2 ventiler, to 3/2 stoppekraner eller med fire 2/2 ventiler eller fire 2/2 stoppekraner.

8.

Arrangement for å operere et lagringselement (8) i et varmetilførselssystem i henhold til hvilke som helst av kravene 6 eller 7,

5 k a r a k t e r i s e r t v e d at ventilene eller stoppekranene kan aktueres med hjelpeenergi.

9.

Arrangement for å operere et lagringselement (8) i et varmetilførselssystem i henhold til hvilke som helst av kravene 1 til 8,

10 k a r a k t e r i s e r t v e d at tilbakestrømsforhindreren (13) er tilveiebragt oppstrøms eller nedstrøms av pumpen (11) eller pumpekaskaden.

10.

Arrangement for å operere et lagringselement (8) i et varmetilførselssystem i henhold til krav 9,

15 k a r a k t e r i s e r t v e d at tilbakestrømsforhindreren (13) tilveiebragt med en strømningskontrollert flottør og/eller en strømningskontrollert klaff og/eller med et strømningskontrollert og fjærbelastet element.

20

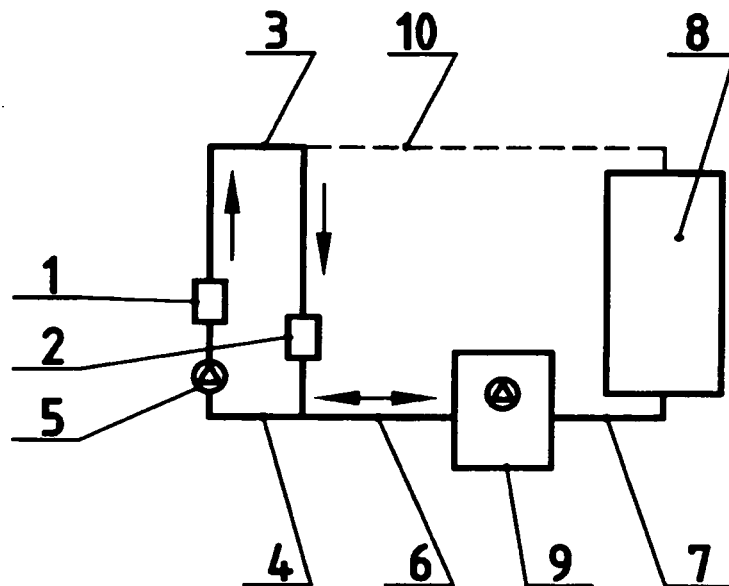
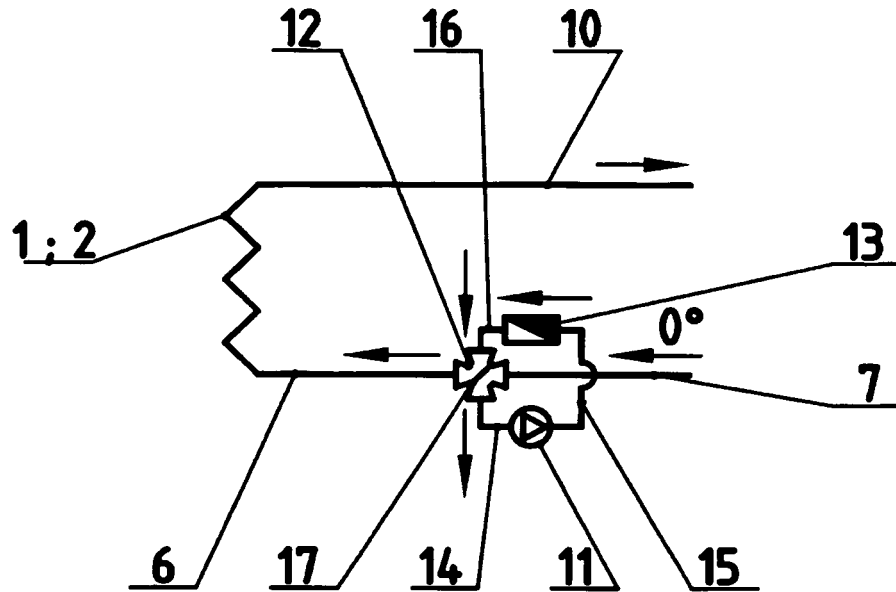
Fig. 1

Fig. 2**Fig. 3**