



(12) APPLICATION

(11) 20180759

(13) A1

NORWAY

(19) NO

(51) Int Cl.

B03C 1/02 (2006.01)

C01B 32/172 (2017.01)

C01B 32/158 (2017.01)

Norwegian Industrial Property Office

(21)	Application nr	20180759	(86)	Int. application day and application nr
(22)	Application day	2018.05.31	(85)	Entry into national phase
(24)	Date from which the industrial right has effect	2018.05.31	(30)	Priority
(41)	Available to the public	2019.12.02		
(71)	Applicant	BERGEN CARBON SOLUTIONS AS, Kokstadflaten 35, 5257 KOKSTAD, Norge		
(72)	Inventor	Jan Børge Sagmo, Vallalia 79, 5227 NESTTUN, Norge Finn Blydt-Svendsen, Nordeidbrekka 34, 5252 SØREIDGREND, Norge		
(74)	Agent or Attorney	HÅMSØ PATENTBYRÅ AS, Postboks 171, 4301 SANDNES, Norge		

(54) Title **Apparatus and method for purification of carbon nanomaterial**
(57) Abstract

The invention relates to an apparatus (1) for purification of carbon nanomaterial, the apparatus (1) comprising a chamber (3) for accepting a solution comprising carbon nanomaterial and a surfactant, wherein the chamber (3) comprises: ultrasonication means (7); an inlet (5) and an outlet (17) for a liquid; and a magnet (13) for creating a magnetic field within the chamber (3), and wherein the apparatus (1) further comprises a filter (15) downstream of the ultrasonication means (7) and the magnet (13). The invention further relates to a method for purifying carbon nanomaterial, the method comprising the steps of: sonicating a solution comprising carbon nanomaterial and a surfactant to disperse the carbon nanomaterial; generating a magnetic field to extract metal particles from the solution; and filtrating the solution to separate carbon nanomaterial from the liquid phase and any additional small particles.

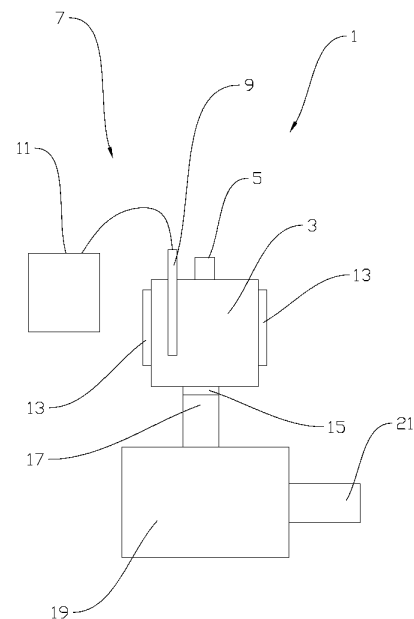

APPARATUS AND METHOD FOR PURIFICATION OF CARBON NANOMATERIAL

The invention relates to an apparatus and a method for purifying carbon nanomaterial.

Carbon nanomaterial (CNM), *e.g.* carbon nanofiber, carbon nanotubes, and graphene, is known to have extraordinary properties, such as having high strength and low weight, and being thermally and electrically conducting. However, their production is expensive and ineffective, and almost always results in the desired type of CNM mixed with some undesired by-product. CNM production is therefore always followed by a purification step if high purity is required.

Various techniques are known for purification of CNM. The two main techniques are based on chemical methods and physical methods, or a combination of the two. However, known techniques or combinations are time consuming and limited to laboratory scale purification. Chemical methods have the disadvantage that the added chemical material may alter the structure of the CNM and thus degrade the physical properties of the CNM. Physical methods are generally less effective than chemical methods. A common and inexpensive physical method for the purification of CNM is filtration, which has the advantage that it does not affect the structure of the CNM. However, simple filtration may be ineffective and only separates the components of the mixture to be filtered based on size. This may be a problem if the smaller components tend to aggregate, for example amorphous carbon, which may thereby be held back in the filter. In summary, known purification methods may have the disadvantages of being expensive and/or ineffective, and they may potentially modify the CNM chemically.

The invention has for its object to remedy or to reduce at least one of the drawbacks of the prior art, or at least provide a useful alternative to prior art. The object is achieved through features, which are specified in the description below and in the claims that follow. The invention is defined by the independent patent claims. The dependent claims define advantageous embodiments of the invention.

In a first aspect, the invention relates more particularly to an apparatus for purification of CNM, the apparatus comprising a chamber for accepting a solution comprising carbon nanofibers and a surfactant, wherein the chamber comprises: ultrasonication means; an inlet and an outlet for a liquid; and a magnet for creating a magnetic field within the chamber; and wherein the apparatus further comprises a filter downstream of the ultrasonication means and the magnet.

The CNM may be *e.g.* carbon nanofibers, carbon nanotubes, or graphene. The CNM may exist at least partially as aggregates, so the ultrasonication means and the surfactant may cooperate for effective and rapid dispersion of the CNM. Ultrasonication will provide vibration to the CNM such

that aggregates of the CNM may temporarily split up into individual CNM molecules. As CNM is generally hydrophobic, the hydrophobic portion of the surfactants will adhere to the CNM, while the hydrophilic portion will face the solution. The CNM will thus be individually and stably dispersed in the solution. As production of CNM often leads to undesired side products such as amorphous carbon, the ultrasonication means may also break up larger aggregates of these side products into smaller parts. The ultrasonication means may for example comprise an ultrasonic probe within the chamber, and the ultrasonic probe may be connected to a power supply outside of the chamber. An ultrasonic probe may have the advantage of being able to provide the chamber with higher effect than e.g. an ultrasonic bath.

The magnetic field will cause any metallic particles, for example originating as a side product from the CNM production, to be extracted from the solution. The production of carbon nanotubes often requires formation of metal nucleation sites, so these metal nucleation sites may therefore be comprised within the mixture to be purified. The magnetic field may be caused by at least one magnet positioned on the chamber, for example a permanent magnet or an electromagnet. The effect of the metal extraction step will be increased by having a stable dispersion of CNM, since no metal particles will be trapped within CNM aggregates.

The filter provides the apparatus with a method for retaining the CNM after metal particles have been extracted and larger aggregates have been broken up. The filter must be positioned such that the solution flows through the filter. The solution, possibly including micelles, monomeric surfactants, and additional components such as amorphous carbon, will be discharged through the filter, while the CNM and CNM-surfactant complexes will be retained in said filter for further use. Depending on the properties of the surfactant and the filter mesh size, micelles may also be trapped by the filter. The apparatus may further comprise a pump downstream of the filter for providing a lower pressure and thereby sucking the solution through the filter. This may improve the efficiency of the apparatus as the flow through the filter will increase.

The combination in a single chamber of ultrasonication, dispersion of the CNM by surfactants, and extraction of metallic particles using a magnetic field increases the efficiency of the apparatus compared to if the steps were performed sequentially at different locations or devices, both in terms of a decrease in the time and manpower needed for filtration and an increase in the resulting degree of purity of the CNM. The increased purity of the CNM is due to the cooperation of the individual steps when performed simultaneously. Ultrasonication helps to disassemble the metallic particles from CNM aggregates, thus causing more metallic particles to be extracted by the magnetic field before they can reassociate with the CNM. If the solution is not subjected to a magnetic field until a later stage, the metallic particles may reassociate with the CNM before they are separated. This could cause some CNM-metal complexes to get caught by the magnetic field, thereby decreasing the CNM yield, and/or some CNM-metal complexes to remain in the filter, whereby all metal particles are not separated from the CNM. Ultrasonication also helps to disassemble any CNM aggregates, whereby the surfactants may better disperse the CNM. Without ultrasonication performed in

presence of surfactants, small aggregates of a few CNM molecules could still be present as complexes with the surfactant molecules, as the individual CNM molecules may have reassociated.

In a second aspect, the invention relates more particularly to a method for purifying carbon nanomaterial using the apparatus according to the first aspect of the invention, the method comprising the steps of: sonicating a solution CNM and a surfactant to disperse the CNM; generating a magnetic field to extract metallic particles from the solution; and filtrating the solution to separate CNM from the liquid phase and any additional small particles. The steps of sonicating a solution comprising CNM and a surfactant and generating a magnetic field to extract metal particles from the solution may be performed simultaneously to obtain higher purity due to beneficial cooperation between the ultrasonication, the presence of the surfactants, and the magnetic field.

The step of filtrating the solution to separate carbon nanomaterial may comprise sucking the solution through the filter using a pump to provide a lower pressure downstream of the filter or pressing the solution through the filter using gas to provide a higher pressure upstream of the filter.

In the following is described an example of a preferred embodiment illustrated in the accompanying drawing, wherein

Fig. 1 shows an apparatus according to the invention.

In the drawing, the reference numeral 1 indicates an apparatus according to the invention. Identical reference numerals indicate identical or similar features. The drawing is presented in a simplified and schematic manner, and the features therein are not necessarily drawn to scale.

Figure 1 shows an apparatus 1 comprising a chamber 3, for example a 300 mm × 300 mm chamber, for accepting a solution comprising carbon nanomaterial and a surfactant through an inlet 5. The chamber 3 comprises ultrasonication means 7, here shown as an ultrasonic probe 9 connected to a power supply 11, and magnets 13 on the side of the chamber 3 creating a magnetic field in the chamber 3. The ultrasonication means 7 provide the energy to break up aggregates of carbon nanomaterial and amorphous carbon, and the magnets 13 remove any metal remnants left from the production process, for example metal particles which have served as nucleation sites. A filter 15 covers the outlet 17 and functions to retain carbon nanomaterial and complexes of carbon nanomaterial and surfactants while letting through amorphous carbon which has been broken down during ultrasonication, and additional surfactants in monomeric and possibly micellar form. The solution which has passed the filter 15 may be collected in an external collecting container 19. Optionally, the solution may be sucked through the filter 15, for example using a pump 21 to provide a lower pressure in the external collecting container 19.

It should be noted that the above-mentioned embodiments illustrate rather than limit the invention, and that those skilled in the art will be able to design many alternative embodiments without departing from the scope of the appended claims. In the claims, any reference signs placed between

parentheses shall not be construed as limiting the claim. Use of the verb "comprise" and its conjugations does not exclude the presence of elements or steps other than those stated in a claim. The article "a" or "an" preceding an element does not exclude the presence of a plurality of such elements.

C l a i m s

1. An apparatus (1) for purification of carbon nanomaterial, the apparatus (1) comprising a chamber (3) for accepting a solution comprising carbon nanomaterial and a surfactant, wherein the chamber (3) comprises:
 - 5 – ultrasonication means (7);
 - an inlet (5) and an outlet (17) for a liquid; and
 - a magnet (13) for creating a magnetic field a within the chamber (3),and wherein the apparatus (1) further comprises a filter (15) downstream of the ultrasonication means (7) and the magnet (13).
- 10 2. The apparatus (1) according to claim 1, wherein the ultrasonication means (7) comprises an ultrasonic probe (9) within the chamber (3).
3. The apparatus (1) according to claim 1 or 2, wherein the apparatus (1) further comprises a pump (21) downstream of the filter (15) for providing a lower pressure and thereby sucking the solution through the filter (15).
- 15 4. A method for purifying carbon nanomaterial using the apparatus (1) according to any of the claims 1-3, the method comprising the steps of:
 - sonicating a solution comprising carbon nanomaterial and a surfactant to disperse the carbon nanomaterial;
 - generating a magnetic field to extract metal particles from the solution; and
 - 20 – filtrating the solution to separate carbon nanomaterial from the liquid phase and any additional small particles.
5. The method according to claim 4, wherein the step of sonicating a solution comprising carbon nanomaterial and a surfactant to disperse the carbon nanomaterial and generating a magnetic field to extract metal particles from the solution are performed simultaneously.
25
6. The method according to claim 4 or 5, wherein the step of filtrating the solution to separate carbon nanomaterial comprises sucking a portion of the solution through the filter (15) using a pump (21) to provide a lower pressure downstream of the filter (15).

7. The method according to claim 4 or 5, wherein the step of filtrating the solution to separate carbon nanomaterial comprises pressing of the solution through the filter (15) using gas to provide a higher pressure upstream of the filter (15).

1/1

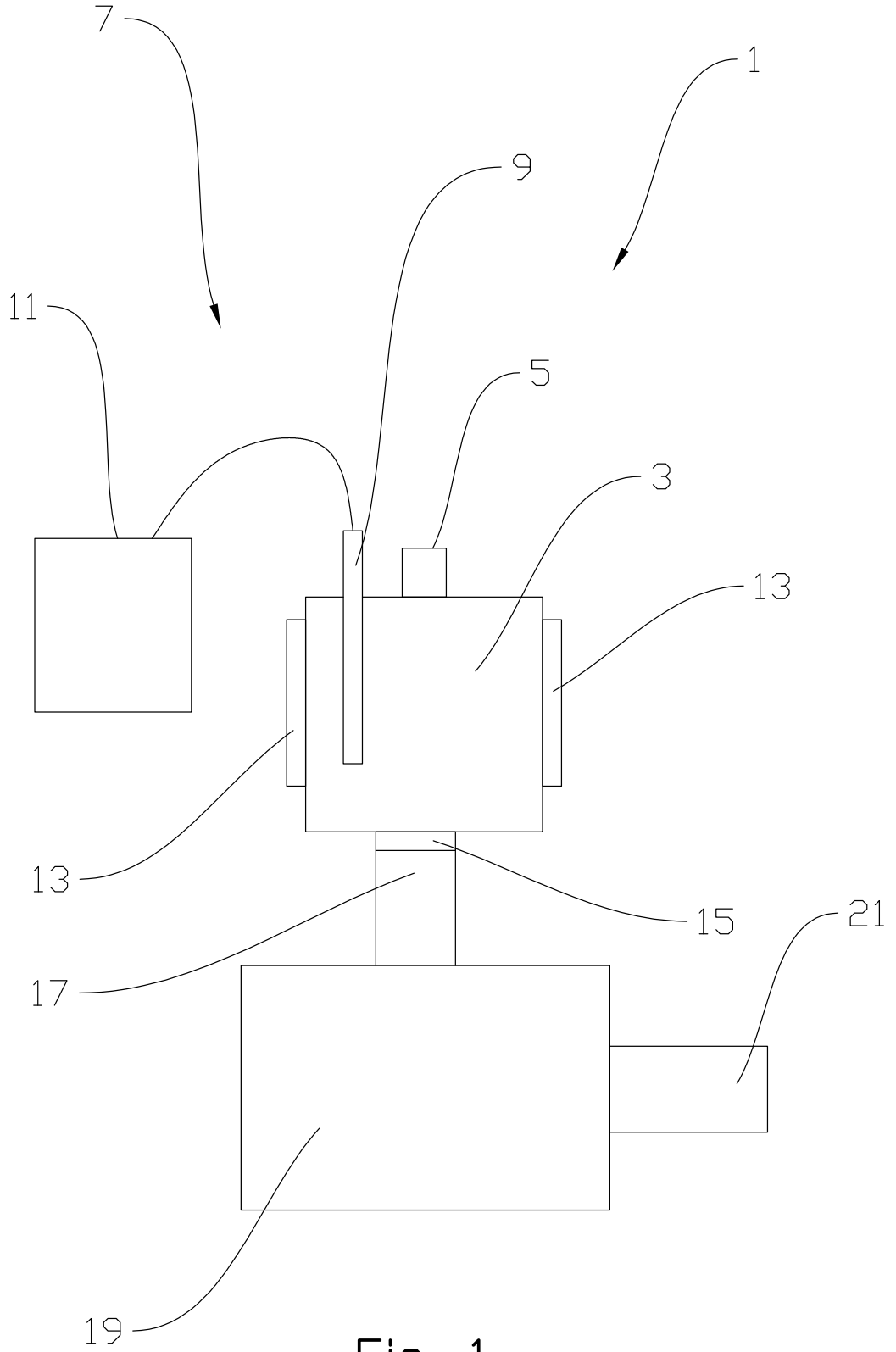

Fig. 1