



(12) PATENT

(11) 343485

(13) B1

NORWAY

(19) NO

(51) Int Cl.

E21B 34/10 (2006.01)

E21B 23/00 (2006.01)

E21B 23/04 (2006.01)

E21B 34/14 (2006.01)

E21B 34/00 (2006.01)

Norwegian Industrial Property Office

(21)	Application nr.	20170851	(86)	International Filing Date and Application Number	
(22)	Date of Filing	2017.05.23	(85)	Date of Entry into National Phase	
(24)	Date of Effect	2017.05.23	(30)	Priority	2016.05.25, NO, 20160892
(41)	Publicly Available	2017.11.27			
(45)	Granted	2019.03.25			
(73)	Proprietor	TCO AS, Postboks 23 Indre Arna, 5888 BERGEN, Norge			
(72)	Inventor	Jan Tore Tveranger, Garnestona 2, 5264 GARNES, Norge			
(74)	Agent or Attorney	ZACCO NORWAY AS, Postboks 2003 Vika, 0125 OSLO, Norge			

(54)	Title	Self Calibrating Toe Valve
(56)	References	
	Cited:	NO 20140616 A1, WO 97/06344 A1, WO 2015/109407 A1
(57)	Abstract	

A toe valve (1) comprising; a housing (200) having an interior and exterior; a sliding sleeve (8); a counter mechanism (2) comprising a cylinder, a ratchet piston (11, 27) with first and second ends, and a ratchet shaft (14, 28) connected to the second end; a trigger assembly (3) comprising a trigger housing, and a release piston (19), wherein the trigger assembly (3) is arranged between the counter mechanism (2) and the sliding sleeve (8), and wherein the release piston (19) is configured to activate the sliding sleeve (8), and the ratchet shaft (14, 28) is configured to activate the release piston (19), wherein the toe valve (1) further comprises; a closed chamber (15) enclosing the ratchet shaft (14, 28) and defined at least partly by the cylinder comprising a chamber fluid with a chamber pressure (P2); an inlet pressure port (6) configured to be in communication with a wellbore fluid with a wellbore pressure (P1), and wherein the first end of the ratchet piston (11, 27) is in fluid communication with the inlet pressure port (6), wherein the ratchet piston (11, 27) is configured to move towards the trigger assembly (3) to a new position and compress the chamber fluid when the wellbore pressure (P1) is larger than the chamber pressure (P2); a retaining mechanism (29) configured to retain the ratchet shaft (14, 28) in the new position; and a valve mechanism interconnecting the first and second ends of the ratchet piston (11, 27) and configured for equalizing the pressure across the ratchet piston (11, 27).

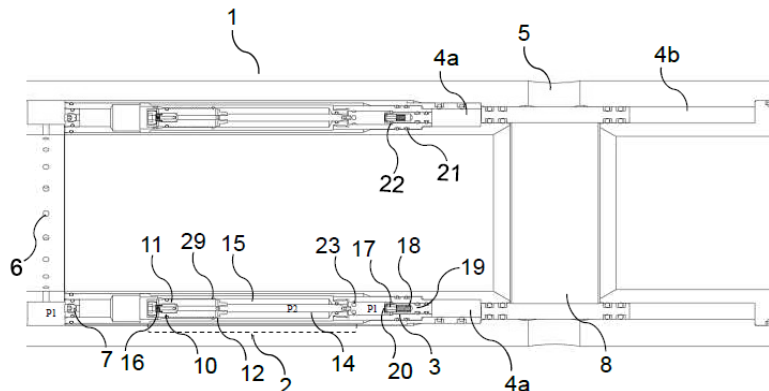

Field of the invention

The invention relates to a self-calibrating Toe Valve installed as a part of casing string in a horizontal wellbore.

Background of the invention

5 The present invention relates to a downhole tool with a sliding sleeve that is shifted into open position using a predetermined pressure operated cycling sequence. The downhole tool may be installed as a part of a casing string in a horizontal wellbore. Normally, after a casing is installed in a wellbore, it is pressure tested to verify the seal integrity. Test operations may include installing two or more plugs in different locations of a
10 wellbore increasing fluid pressure from the surface in order to record possible leaks between the plugs. Typically, a pressure drop in and/or a loss fluid between the plugs will be a sign of breached well integrity. After casing pressure test, a port is opened in the toe of the well in order to pump down equipment, example equipment for fracking. Toe valves are typically used for this purpose. Toe valves are initially closed, but they
15 can be opened to stimulate various intervals in the well.

NO 20140616 A1 relates to an actuator that may be used in a wellbore to change the state of a downhole tool. The actuator has an operator that is axially moveable in response to changes in tubing pressure. The actuator includes a hydraulic circuit that
20 creates a temporary reference pressure against which the tubing pressure indexes the operator.

WO 97/06344 A1 discloses an apparatus for use in setting packers and other fluid actuated devices comprises a tubular body (222), a valve (228) for controlling the flow
25 of well fluid through a port (234) in the body (222) and a valve actuator (224) mounted on the body (222) and movable relative thereto, to open the valve (228) by application of well fluid pressure. The well fluid may flow through the open valve (228) to set a packer or actuate a device.

WO2015/109407 A1 relates to a multistage high pressure fracturing system and tubular hydraulic valve (THV) system for connection to a completion string to enable isolation of a zone of interest within a well. In particular, the system enables access to a downhole formation for fracturing the zone of interest and for hydrocarbon production.

5 The system generally includes a plug counting system, a plug capture system and a valve system wherein dropping a series of plugs down the completion string enables successive capture of individual plugs within individual THVs for subsequent fracturing operations.

10 Different types of Toe valves are disclosed in US2016/0237785 A1. In particular US2016/0237785 A1 discloses a downhole tool that is actuatable in response to applied pressure. The tool has a housing, an insert, and an indexer. The housing defines a housing bore therethrough and defines at least one port communicating the housing bore outside the housing. The housing has a communication path extending from a first part
15 of the housing bore to a second part of the housing bore. The insert is movably disposed in the housing bore and sealably encloses the second part of the communication path. The insert is movable from a first position covering the at least one port to a second position uncovering the at least one port.

20 The indexer is disposed in the communication path and is movably responsive to the applied pressure at the first part of the communication path. The indexer counts a number of applications of the applied pressure and permits fluid communication of the applied pressure from the first part to the second part in response to the counted number. At least a portion of the insert acted upon by the applied fluid pressure in the
25 second part initiates movement of the insert from the first position to the second position.

The indexer includes a piston having first and second piston portions. The first piston portion is movably responsive to the applied pressure at the first part and moves the
30 second piston portion relative to sealed engagement with the second part. The first piston portion includes a ring movably disposed in a first internal space of the first part. The second piston portion includes at least one rod connected to the ring and movable

therewith. The at least one rod in a first condition prevents communication of the applied pressure from the first internal space to the second part of the communication path and in a second condition permits the communication of the applied pressure from the first internal space to the second part.

5

It is well known to use an indexer for enabling activation of various well equipment to initiate a necessary action, and where the equipment is activated by pulsing or cycling the pressure of the fluid that is in the well. Normally, such indexers are constructed by a counting and step construction (counter system) where a piston or the like displaces a
10 toothed rod, ratchet, shaft or the like a given distance each time the operator on the surface increases the fluid pressure in the well, with such a pressure increase being followed by a pressure release. When the rod, after a given number of such pulses with high/low fluid pressure, has been moved a sufficient distance forwards, activation of various equipment in a hydrocarbon well is enabled.

15

Conventional counter systems largely must be calibrated to specific well conditions and may fail to work if pressure conditions in a well change or are otherwise outside the pressure intervals under which the calibrated trigger system is set to work.

20 With the help of the counter system, the time of activation can be accurately predicted as it is based on the number of pressure cycles to the release and not on the level of fluid pressure. However, these systems can still be improved.

Calibrating a trigger system is a time-demanding operation, as each tool must be
25 calibrated for the specific well conditions. In addition, well conditions may change, thereby moving the pressure and temperature conditions outside the operating pressure window of the trigger systems.

Today's systems also require that the pipe has a higher material thickness to solve the
30 problem, as one traditionally needs to use a very powerful spring or a nitrogen chamber to compensate for the hydraulic fluid pressure of the well.

Therefore, it is an aim of the invention to provide a new construction that can eliminate the need for calibration of the Toe valve tool for each individual well in which the Toe Valve is to be used.

5 Furthermore, it is an aim to provide a Toe Valve system that is self-calibrating based on hydrostatic pressure.

Furthermore, it is an aim to be able to contribute to maintaining the pressure that must be applied from the surface to the pipe at the same level, regardless of the depth and
10 temperature in which the toe valve is fitted.

At least one of these aims is achieved by the device indicated in the enclosed independent claim 1. Other favorable or possible embodiments are indicated in the dependent claims.

15

Summary of the invention

A toe valve comprising; a housing having an interior and exterior; a sliding sleeve; a counter mechanism comprising a cylinder, a ratchet piston with first and second ends, and a ratchet shaft connected to the second end; a trigger assembly comprising a trigger
20 housing, and a release piston, wherein the trigger assembly is arranged between the counter mechanism and the sliding sleeve; and wherein the release piston is configured to activate the sliding sleeve, and the ratchet shaft is configured to activate the release piston; wherein the toe valve further comprises a closed chamber enclosing the ratchet shaft and defined at least partly by the cylinder comprising a chamber fluid with a
25 chamber pressure (P2); an inlet pressure port configured to be in communication with a wellbore fluid with a wellbore pressure (P1), and wherein the first end of the ratchet piston is in fluid communication with the inlet pressure port, wherein the ratchet piston is configured to move towards the trigger assembly to a new position and compress the chamber fluid when the wellbore pressure (P1) is larger than the chamber pressure (P2);
30 a retaining mechanism configured to retain the ratchet shaft in the new position, and; a

valve mechanism interconnecting the first and second ends of the ratchet piston and configured for equalizing the pressure across the ratchet piston.

5 In one embodiment of the invention the toe valve further comprises at least one frack port having a perforation extending from the interior of the housing to the exterior of the housing wherein the sliding sleeve is arranged to cover the at least one frack port.

In one embodiment of the invention the valve mechanism is arranged within the ratchet piston.

10

In one embodiment of the invention the valve mechanism comprises a valve configured to prevent fluid flow in a first direction from inlet pressure port to the closed chamber and allow fluid flow in a second opposite the first direction.

15 In one embodiment of the invention the valve is one-way relief valve. The valve may comprise a ball arranged to rest on a seat. The valve may be configured to open when the ball is moved away from the seat.

20 In one embodiment of the invention the valve mechanism comprises a first one-way valve and a second one-way valve each having one end in fluid communication with the closed chamber and another end in pressure communication with the inlet pressure port, wherein the first and the second one-way valves are arranged in opposite directions.

25 In one embodiment of the invention the valve mechanism is configured to equalize pressure in the closed chamber when a predetermined differential pressure value between P1 and P2 is exceeded.

30 In one embodiment of the invention the first valve is configured to open when pressure at the inlet pressure port is a predetermined value greater than the chamber pressure in the closed chamber.

In one embodiment of the invention the second valve is configured to open when wellbore

pressure (P1) at the inlet pressure port is a predetermined value less than the chamber pressure (P2) in the closed chamber.

In one embodiment of the invention the fluid in the closed chamber is a compressible fluid
5 and the compressible fluid in the closed chamber is silicone oil.

In one embodiment of the invention the cylinder further comprises a retaining member configured to limit movement of the ratchet shaft towards the inlet pressure port. In another embodiment of the invention the cylinder further comprises a retaining shoulder
10 configured to limit the movement of the ratchet piston towards the closed chamber.

In one embodiment of the invention the toe valve further comprising an activation pin configured to release the release piston, and a first atmospheric chamber arranged between the trigger assembly and the sliding sleeve, wherein the release piston is configured to
15 compress the first atmospheric chamber when released by the activation pin.

In one embodiment of the invention the toe valve further comprises pressure equalization channel which extends from the inlet pressure port and beyond the ratchet piston assembly.

20 In one embodiment of the invention the toe valve further comprises a second atmospheric chamber arranged opposite the first atmospheric chamber relative to the sliding sleeve, wherein the sliding sleeve is configured to move in response to pressure difference between the first atmospheric chamber and the second atmospheric chamber.

25 It is also provided a method of opening toe valve comprising; a housing having an interior and exterior; a sliding sleeve, a counter mechanism comprising a cylinder, a ratchet piston with first and second ends, and a ratchet shaft connected to the second end; a trigger assembly comprising a trigger housing, and a release piston, wherein the trigger assembly is arranged between the counter mechanism and the sliding sleeve; and
30 wherein the toe valve further comprises a closed chamber enclosing the ratchet shaft and defined at least partly by the cylinder comprising a chamber fluid with a chamber pressure (P2); an inlet pressure port configured to be in communication with a wellbore

fluid with a wellbore pressure (P1), and wherein the first end of the ratchet piston is in fluid communication with the inlet pressure port; a retaining mechanism, and a valve mechanism interconnecting the first and second ends of the ratchet piston, the method comprising the steps of;

5 activating the counter mechanism, wherein the activation of the counter mechanism comprising the steps of;

a) increasing wellbore pressure (P1) at the inlet pressure port to push the ratchet piston towards the trigger assembly whereby the ratchet piston compresses the fluid in the closed chamber, and to move the ratchet shaft is to a new position;

10 b) retaining the ratchet shaft in the new position by the retaining mechanism;

c) continue increasing wellbore pressure (P1);

d) decreasing the wellbore pressure (P1) lower than chamber pressure (P2);

e) open the valve mechanism to equalize pressure across the ratchet piston by releasing fluid from the closed chamber;

15 f) repeating steps a) to e) until the ratchet shaft engages with the activation pin and forces the activation pin from its position towards the release piston;

Activating the trigger assembly, wherein the activation of the trigger assembly comprising the steps of;

20 pushing the release piston with the activation pin towards the first atmospheric chamber, thereby increasing the pressure in the atmospheric chamber;

pushing the sliding sleeve away from the at least one frack port towards the second atmospheric chamber with the release piston;

25 It is also provided a method of opening toe valve comprising; a housing having an interior and exterior; a sliding sleeve, a counter mechanism comprising a cylinder, a ratchet piston with first and second ends, and a ratchet shaft connected to the second end; a trigger assembly comprising a trigger housing, and a release piston, wherein the

trigger assembly is arranged between the counter mechanism and the sliding sleeve; and wherein the toe valve further comprises a closed chamber enclosing the ratchet shaft and defined at least partly by the cylinder comprising a chamber fluid with a chamber pressure (P2); an inlet pressure port configured to be in communication with a wellbore fluid with a wellbore pressure (P1), and wherein the first end of the ratchet piston is in fluid communication with the inlet pressure port; a retaining mechanism, and a valve mechanism interconnecting the first and second ends of the ratchet piston, the method comprising the steps of;

activating the counter mechanism, wherein the activation of the counter mechanism comprising the steps of;

- a) increasing wellbore pressure (P1) at the inlet pressure port to push the ratchet piston towards the trigger assembly whereby the ratchet piston compresses the fluid in the closed chamber, and to move the ratchet shaft to a new position;
- b) retaining the ratchet shaft in the new position by the retaining mechanism;
- c) continue increasing wellbore pressure (P1) until a pressure difference between P1 and P2 exceeds a predetermined pressure difference;
- d) open a first valve of the valve mechanism to equalize pressure across the ratchet piston by allowing fluid into the closed chamber;
- e) decreasing the wellbore pressure (P1) to a pressure value lower than chamber pressure (P2), where a pressure difference between P1 and P2 exceeds a predetermined pressure difference;
- f) open a second valve of the valve mechanism to equalize pressure across the ratchet piston by releasing fluid from the closed chamber;
- g) repeating steps a) to f) until the ratchet shaft engages with the activation pin and forces the activation pin from its position towards the release piston;

Activating the trigger assembly, wherein the activation of the trigger assembly comprising the steps of;

pushing the release piston with the activation pin towards the first atmospheric chamber, thereby increasing the pressure in the atmospheric chamber;

pushing the sliding sleeve away from the at least one frack port towards the second atmospheric chamber with the release piston;

- 5 In one embodiment of the invention, in step f), the ratchet piston is pushed back to its start position and the ratchet shaft is retained by the retaining mechanism.

Brief description of the drawings

These and other possible alternative or advantageous embodiments of the invention will
10 become clear from the following detailed description of an embodiment, given as non-limiting examples, with reference to the attached schematic drawings, wherein:

Figure 1 shows the device according of the invention.

Figure 2 is a section of the device according of the invention.

Figure 3 shows one embodiment of the invention.

15 Detailed description

The following description may use terms such as “horizontal”, “vertical”, “lateral”, “back and forth”, “up and down”, “upper”, “lower”, “inner”, “outer”, “forward”, “rear”, etc. These terms generally refer to the views and orientations as shown in the drawings and that are associated with normal use of the invention. The terms are used for the
20 reader’s convenience only and shall not be limiting.

In one embodiment of the invention, the toe valve device 1 is shown in figure 1. The device 1 is inserted in a tubing 100, the device comprises a housing 200 defining a housing bore comprising a self-calibrating counter mechanism 2, a sliding sleeve 8 covering at least one frack port 5 in a closed configuration and uncovering at least one
25 frack port 5 in an open configuration, at least one frack port is in communication outside the housing 200, a trigger assembly 3 which is configured to open and activate the sliding sleeve 8 into an atmospheric chamber 4b and thus opening at least one frack

port 5, the trigger assembly 3 comprising a trigger housing, an activation pin 17 and a release piston 19. The toe valve may further comprise an inlet pressure port 6 in a first end in communication with the counter mechanism 2 for activating the counter mechanism 2 and in a second end in communication with a wellbore pressure (P1) which may be manipulated from a rig, vessel or by a pressure manipulator in/on a wellhead. The inlet pressure ports 6 may be a perforated sleeve forming a protected chamber where debris and cement fallout can settle on without clogging off inlet pressure ports 6. The device 1 further comprises a fluid separation piston 7 located above the inlet pressure port 6 arranged to ensure that the counter mechanism 2 always operates in clean fluids and a retaining mechanism 10 for limiting backward movement of the counter mechanism 2.

Figure 2 shows a section of figure 1. The counter mechanism 2 of the device 1 comprises a cylinder with a closed chamber 15 filled with a compressible fluid having a chamber pressure (P2), preferably a silicone oil, a ratchet assembly 12 which comprises a ratchet piston 11 and a ratchet shaft 14. The ratchet piston 11 and the ratchet shaft 14 may be a single unit or different units welded together or attached to each other by fastenings means. The counter mechanism 2 further comprises a valve mechanism interconnecting the inlet pressure port 6 and the closed chamber 15 and is arranged for equalizing the pressure across the ratchet piston 11. The valve mechanism comprises a valve 16 which may be a one-way relief valve or a check valve. The valve 16 may be configured to prevent fluid flow in a first direction from inlet pressure port 6 to the closed chamber 15 and allow fluid flow in a second opposite the first direction. The valve mechanism may be arranged within the ratchet piston 11 or arranged behind the ratchet piston 11.

The device 1 further comprises a trigger assembly 3 arranged between the counter mechanism 2 and the sliding sleeve 8, the trigger assembly 3 comprising an activation pin 17, spring 18 attached to the activation pin 17, a release piston 19 located at the front end of the activation pin 17 and the spring 18 for pushing the sliding sleeve 8 to expose the at least one frack port 5. The release piston 19 may be exposed to a wellbore pressure P1 on the activation pin 17 side by a pressure communication channel 23 which extends from the inlet pressure port 6 and beyond the counter mechanism 2. The

trigger assembly 3 further comprises a first atmospheric chamber 4a arranged between the release piston 19 and the sliding sleeve 8. The release piston 19 may be configured to slide in the first atmospheric chamber 4a when it is pushed by the activation pin 17. The trigger assembly 3 may further comprise a c-clip 20, plurality of O-rings 21 and a locking elements 22 for sealing and locking the trigger assembly 3 in place.

The toe device 1 is open by a predetermined pressure cycle. P1 is the wellbore pressure that is being manipulated by increasing and decreasing it. In the first pressure cycle, the pressure P1 at the inlet pressure port is increased. When P1 is increased, the ratchet assembly 12 is pushed inward and starts to compress the fluid in the closed chamber 15. As the pressure (P1) continues to increase, the ratchet shaft 14 moves further towards the activation pin 17 and the ratchet assembly 12 will compress the compressible fluid in the closed chamber 15 to a point where a further compression of the fluid in closed chamber 15 is not achieved. The first pressure cycle is complete when the compressible fluid can no longer be compressed by increasing P1 and the pressure P2 in the closed chamber 15 is higher than its initial value. To further progress the ratchet assembly 12 towards the activation pin 17, it is preferable to reduce the fluid volume in the closed chamber 15. This is achieved by decreasing the pressure P1 to a value lower than chamber pressure P2. As the pressure P1 decreases to a value lower than the chamber pressure P2 in the closed chamber 15, the fluid in the closed chamber 15 forces the ratchet shaft 14 to move backward towards the inlet pressure port 6. However, backward movement of the ratchet shaft 14 is not desirable and is prevented by the retaining mechanism 29. The valve 16 is in fluid/pressure communication with the closed chamber 15 and is affected by the force of the compressible fluid in the closed chamber, meaning that pressure is applied to the valve 16 by the compressible fluid. The valve 16 may comprise a ball resting on a seat which enables the valve 16 to open when the ball is moved away from its seat. The valve is configured to open when a predetermined pressure difference between P2 and P1, set by the user, is exceeded. Optionally, the valve 16 may be configured to open at a specific predetermined crack-open pressure. When the predetermined pressure difference between P2 and P1 set by the user is exceeded, the valve 16 opens. This results in fluid outflow from the chamber 15, and the pressure difference between P1 and P2 is equalized. After pressure

equalization is achieved or nearly achieved, the pressure P1 is increased again to move the ratchet assembly 12 further inward towards the activation pin 17. This pressure increase is counted as the second pressure cycle. As the pressure P1 increases, the ratchet assembly 12 compresses the fluid in the closed chamber 15 and progresses
5 further towards the activation pin 17, since there is less fluid in the closed chamber 15 than there was under the first pressure cycle. This pattern/process is repeated until the ratchet shaft 14 pushes the activation pin 17 away from its position. The activation pin 17 may be held in place by a retaining-clip 20 and locking elements 22. When the ratchet shaft 14 engages with the retaining-clip 20, the ratchet shaft 14 pushes the
10 activation pin 17 out of its position towards the release piston 19. The release piston 19 is exposed to wellbore pressure P1 or ratchet assembly pressure on a first end and a first atmospheric chamber 4a arranged between the trigger assembly and the sliding sleeve on a second end. The activation pin 17 is configured to force the release piston 19 towards the atmospheric chamber 4a to equalize the pressure difference between the
15 first atmospheric chamber 4a side and the activation pin 17 side. The atmospheric chamber 4a,b is a chamber that holds a pressure of 1 atmosphere (1 bar). The sliding sleeve 8 is configured to move in response to the pressure difference between the first atmospheric chamber 4a and the second atmospheric chamber 4b arranged opposite the first atmospheric chamber 4a. The release piston 19 pushes the sliding sleeve 8 away
20 from the frack ports 5 as the result of pressure equalization between the atmospheric chambers 4a,b. After the frack ports 5 in the toe valve 1 are opened, the well is ready for treatment operations, for example fracking.

The toe valve according to the invention is self-calibrating because when the pressure in the downhole changes due to temperature, depth or fluid weights, the closed chamber 15
25 will equalize to the downhole pressure by means of the valve 16 bleeding off excess volume, or the ratchet assembly 12 moving inward for volume compensation.

In one embodiment of the invention the device 1 comprises another type of counter mechanism. Figure 3 shows a simplified hydraulic diagram of this embodiment of the invention. The figure shows a pressure, P1, which is the pressure at the rear of the
30 device 1 (wellbore pressure), rear in this regard being the left side. The pressure equalization channel 23 extends from the inlet pressure port 6 and beyond a counter

mechanism 25. The pressure equalization channel 13 avoids pressure buildup between the front and the rear of the device 100. P1 is the pressure that is being manipulated by increasing and decreasing it.

5 In figure 3, the counter mechanism 25 comprises the ratchet assembly 26 comprising a ratchet piston 27 and a ratchet shaft 28, the ratchet shaft 28 which is movably connected to the ratchet piston 27, retaining mechanism 29 in contact with the exterior part of the ratchet 28 and a retaining member 30 in contact with the front end of the ratchet. Both the retaining mechanism 29 and the retaining member 30 act/serve to limit backward
10 movement of the ratchet shaft 28. The counter 25 further comprises a retaining shoulder 31 for restricting movement of the ratchet piston 27 and a closed chamber 15 filled with a compressible fluid. The ratchet piston 27 is configured to displace the ratchet shaft 28 in a direction towards the front end of the counter mechanism (inward) and move freely in the other direction (outward). The compressible fluid in the closed chamber 15 is a
15 compressible liquid, preferably silicone oil. The counter mechanism 25 may further comprise resilient elements (not shown) located behind the ratchet piston 27 or behind the ratchet shaft 28. The device further comprises a valve mechanism 32 interconnecting the inlet pressure port 6 and the closed chamber 15 arranged for equalizing the pressure across the ratchet piston 27. The valve mechanism 32 comprises a first one-way valve 33a
20 and a second one-way valve 33b each having one end in fluid communication with the closed chamber 15 and another end in pressure communication with the inlet pressure port 6, the first and the second one-way valves are arranged in opposite directions.

P2, which is shown in figure 3, is the pressure in the closed chamber 15. When the pressure at the rear of the device, P1, is increased, the ratchet piston 27 and the ratchet
25 shaft 28 move inward and start to compress the fluid in the closed chamber 15. The pressure in the closed chamber 15 increases as a result of this fluid compression. When the pressure difference between P1 and P2 exceeds a predetermined value, the first valve 33a opens to equalize this pressure difference. When the pressure at rear of the device, P1, is decreased and a predetermined pressure difference between P2 and P1 is
30 exceeded, the second valve 33b opens to equalize the pressure difference. The backward

and the forward movements of the ratchet piston 27 are controlled by P1, P2 and the valves. P3 shown in the figure is the pressure in the atmospheric chamber.

When pressure P1 is increased, the ratchet piston 27 is forced to move inward, compressing the fluid in the closed chamber 15. As the ratchet piston 27 moves inward, it displaces the ratchet shaft 28 inward. As the pressure (P1) is increased, the ratchet piston 27 moves until it is retained by the retaining shoulder 31. The pressure, P1, continues to increase until a predetermined differential pressure value (P1-P2) is exceeded. The first valve 33a is configured to open when this predetermined differential pressure value is exceeded. This results in a fluid influx in the closed chamber 15 and pressure equalization in the closed chamber 15 is achieved. After pressure equalization is achieved, the ratchet piston 27 is moved back to its original position (outward). This is achieved by decreasing P1 and opening the second valve 33b. P1 is decreased until a predetermined differential pressure value between P1 and P2 is exceeded. The second valve 33b is configured to open when this predetermined differential pressure value (P2-P1) is exceeded. This result in fluid decompression and fluid outflux from the closed chamber 15 and pressure equalization between P1 & P2.

Outward movement (direction towards the rear of the counter mechanism) of the ratchet piston 27 is achieved when P2 exceeds P1, but before exceeding the predetermined differential pressure to open the second valve 33b. As the ratchet piston 27 moves outward, the ratchet shaft 28 is retained by the retaining rings 29 and the retaining member 30, thereby achieving outward movement of the ratchet piston 27 only. One pressure cycle is completed when the ratchet piston 27 is moved back to its original position. This process is repeated until the ratchet shaft 28 reaches an activation pin 17. The ratchet shaft 28 moves towards the activation pin 17 for every pressure cycle until it reaches the activation pin 17 which activates the release piston and the sliding sleeve and thus opening the frack ports.

The valves 33a,b are configured to equalize pressure in the closed chamber 15. The valves operate in opposite directions and open at a predetermined differential pressure. The term “predetermined” means a pressure value that is preset by the manufacturer or the user. Differential pressure in this regard means a pressure difference between P1 and

P2 or vice versa, $P1-P2$ or $P2-P1$. In the present application, the differential pressure may also be referred to as crack-open pressure. In one embodiment of the invention, the first valve 33a is configured to open when $P1-P2 = 80$ bar (crack-open pressure). When the crack-open pressure is exceeded, the valve opens to equalize the pressure in the closed chamber 15 by pumping more fluid into the chamber 15. In the same embodiment of the invention, the second valve 33b has a crack-open pressure of 20 bar ($P2-P1 = 20$ bar). As P2 exceeds P1, but before P2 exceeds the crack-open pressure of the second valve 2b, the ratchet piston 27 moves outward, because P2 is larger than P1. It should be understood that the pressure difference that is needed to achieve outward movement of the ratchet piston 27 should be greater than its frictional force. After P2 exceeds the crack-open pressure of the second valve (20 bar), the second valve 33b opens to equalize the pressure in the closed chamber by bleeding off fluid from the chamber 15. In this embodiment, the valves operate at crack open pressures of 80 bar and 20 bar, respectively. It should be understood that the valves can be designed to operate at other crack-open pressures than the values used in this embodiment. The values used in this embodiment are presented for the reader's convenience and shall not be understood as limiting.

Due to the valves, the device according to this embodiment of the invention is self-calibrating. The device can be activated regardless of the pressure range in the well. The activation of the device is controlled by the differential pressure between the fluid in the closed chamber, P2, and the surrounding pressure, P1, which is remotely manipulated.

While the invention has been described with reference to the embodiment illustrated, it should be understood that modifications and/or additions can be made to the device.

Claims

1. A toe valve (1) comprising;
 - a housing (200) having an interior and exterior;
 - 5 - a sliding sleeve (8);
 - a counter mechanism (2), **characterized in that** the counter mechanism comprising;
 - a cylinder,
 - a ratchet piston (11, 27) with first and second ends, and
 - a ratchet shaft (14, 28) connected to the second end,
 - 10 - a trigger assembly (3) comprising;
 - a trigger housing, and
 - a release piston (19), wherein
 - the trigger assembly (3) is arranged between the counter mechanism (2) and the sliding sleeve (8), and wherein
 - 15 - the release piston (19) is configured to activate the sliding sleeve (8), and
 - the ratchet shaft (14, 28) is configured to activate the release piston (19), wherein the toe valve (1) further comprises;
 - a closed chamber (15) enclosing the ratchet shaft (14, 28) and defined at least by the cylinder comprising a chamber fluid with a chamber pressure (P2);
 - 20 - an inlet pressure port (6) configured to be in communication with a wellbore fluid with a wellbore pressure (P1), and wherein the first end of the ratchet piston (11, 27) is in fluid communication with the inlet pressure port (6), wherein the ratchet piston (11, 27) is configured to move towards the trigger assembly (3) to a new position and compress the chamber fluid when the wellbore pressure (P1) is larger than the chamber pressure
 - 25 (P2);
 - a retaining mechanism (29) configured to retain the ratchet shaft (14, 28) in the new position; and
 - a valve mechanism interconnecting the first and second ends of the ratchet piston (11, 27) and configured for equalizing the pressure across the ratchet piston (11, 27).
 - 30
2. The toe valve according to claim 1, further comprising at least one frack port having a perforation extending from the interior of the housing (200) to the exterior of

the housing (200) wherein the sliding sleeve (8) is arranged to cover the at least one
frack port (5).

3. The toe valve according to claim 1, wherein the valve mechanism is arranged
5 within the ratchet piston (11).

4. The toe valve according to claim 3, wherein the valve mechanism comprises a
valve (16) configured to prevent fluid flow in a first direction from inlet pressure port (6)
to the closed chamber (15) and allow fluid flow in a second opposite the first direction.

10

5. The toe valve according to claim 4, wherein the valve (23) is one-way relief valve.

6. The toe valve according to claim 4 or 5, wherein the valve comprises a ball arranged
to rest on a seat.

15 7. The toe valve according to claim 6, wherein the valve (23) is configured to open
when the ball is moved away from the seat.

8. The toe valve according to claim 1, wherein the valve mechanism comprises a first
one-way valve (33a) and a second one-way valve (33b) each having one end in fluid
20 communication with the closed chamber (15) and another end in pressure communication
with the inlet pressure port (6), wherein the first and the second one-way valves are
arranged in opposite directions.

9. The toe valve according to claim 1, wherein the valve mechanism is configured to
25 equalize pressure in the closed chamber (15) when a predetermined differential pressure
value between P1 and P2 is exceeded.

10. The toe valve according to claim 1, wherein the fluid in the closed chamber (15) is
a compressible fluid.

30

11. The toe valve according to claim 1, wherein the cylinder further comprises:
a retaining member (30) configured to limit movement of the ratchet shaft (28)

towards the inlet pressure port (6).

12. The toe valve according to claim 1, wherein the cylinder further comprises:
a retaining shoulder (31) configured to limit the movement of the ratchet piston
5 (27) towards the closed chamber (15).
13. The toe valve according to claim 1, wherein the toe valve further comprising:
An activation pin (17) configured to release the release piston (19), and a first
atmospheric chamber (4a) arranged between the trigger assembly (3) and the
10 sliding sleeve (8), wherein the release piston (19) is configured to compress the
first atmospheric chamber (4a) when released by the activation pin (17).
14. The toe valve according to claim 8, wherein the first valve (33a) is configured to
open when pressure (P1) at the inlet pressure port (6) is a predetermined value
15 greater than the chamber pressure (P2) in the closed chamber (15).
15. The toe valve according to claim 8, wherein the second valve (33b) is configured
to open when pressure (P1) at the inlet pressure port (6) is a predetermined value
less than the chamber pressure (P2) in the closed chamber (15).
20
16. The toe valve according to claim 1, further comprising pressure equalization
channel (23) which extends from the inlet pressure port (6) and beyond the ratchet
piston assembly (12).
- 25 17. The toe valve according to claim 10, wherein the compressible fluid in the closed
chamber (15) is silicone oil.
18. The toe valve according to claim 1, further comprising a second atmospheric
chamber (4b) arranged opposite the first atmospheric chamber (4a) relative to the
sliding sleeve (8), wherein the sliding sleeve (8) is configured to move in response
30 to pressure difference between the first atmospheric chamber and the second
atmospheric chamber.

19. A method of opening toe valve (1), **characterized in that** the toe valve comprising;
- a housing (200) having an interior and exterior,
 - a sliding sleeve (8),
 - 5 - a counter mechanism (2) comprising;
 - a cylinder,
 - a ratchet piston (11) with first and second ends, and
 - a ratchet shaft (14) connected to the second end,
 - a trigger assembly (3) comprising;
 - 10 - a trigger housing, and
 - a release piston (19), wherein
 - the trigger assembly (3) is arranged between the counter mechanism (2) and the sliding sleeve (8), and wherein the toe valve (1) further comprises;
 - a closed chamber (15) enclosing the ratchet shaft (14) and defined at least the cylinder comprising a chamber fluid with a chamber pressure (P2),
 - 15 - an inlet pressure port (6) configured to be in communication with a wellbore fluid with a wellbore pressure (P1), and wherein the first end of the ratchet piston (11) is in fluid communication with the inlet pressure port (6),
 - a retaining mechanism (29), and
 - 20 - a valve mechanism interconnecting the first and second ends of the ratchet piston (11),
- the method comprising the steps of;
- Activating the counter mechanism (2), wherein the activation of the counter mechanism comprising the steps of;
- a) increasing wellbore pressure (P1) at the inlet pressure port (6) to push the
 - 25 ratchet piston (11) towards the trigger assembly (3) whereby the ratchet piston (11) compresses the fluid in the closed chamber (15), and to move the ratchet shaft (14) is to a new position,
 - b) retaining the ratchet shaft in the new position by the retaining mechanism (29);
 - 30 c) continue increasing wellbore pressure (P1);

d) decreasing the wellbore pressure (P1) lower than chamber pressure (P2);

e) open the valve mechanism (6) to equalize pressure across the ratchet piston (11) by releasing fluid from the closed chamber (15);

f) repeating steps a) to e) until the ratchet shaft (14) engages with the activation pin (17) and forces an activation pin (17) from its position towards the release piston (19);

activating the trigger assembly (3), wherein the activation of the trigger assembly (3) comprising the steps of;

pushing the release piston (19) with the activation pin (17) towards the first atmospheric chamber (4a), thereby increasing the pressure in the atmospheric chamber (4a);

pushing the sliding sleeve (8) away from the at least one frack port (5) towards the second atmospheric chamber (4b) with the release piston (19);

20. A method of opening toe valve (1), **characterized in that** the toe valve comprising;

- a housing (200) having an interior and exterior,

- a sliding sleeve (8),

- a counter mechanism (2) comprising;

- a cylinder,

- a ratchet piston (27) with first and second ends, and

- a ratchet shaft (28) connected to the second end,

- a trigger assembly (3) comprising;

- a trigger housing, and

- a release piston (19), wherein

- the trigger assembly (3) is arranged between the counter mechanism (2) and the sliding sleeve (8), and wherein the toe valve (1) further comprises;

- a closed chamber (15) enclosing the ratchet shaft (28) and defined at least by the cylinder comprising a chamber fluid with a chamber pressure (P2),

- an inlet pressure port (6) configured to be in communication with a wellbore fluid with a wellbore pressure (P1), and wherein the first end of the ratchet piston (27) is in fluid communication with the inlet pressure port (6),
- a retaining mechanism (29), and
- 5 - a valve mechanism interconnecting the first and second ends of the ratchet piston (27), the method comprising the steps of;
activating the counter mechanism (2), wherein the activation of the counter mechanism comprising the steps of;
 - 10 a) increasing wellbore pressure (P1) at the inlet pressure port (6) to push the ratchet piston (27) towards the trigger assembly (3) whereby the ratchet piston (27) compresses the fluid in the closed chamber (15), and to move the ratchet shaft (28) to a new position,
 - b) retaining the ratchet shaft (28) in the new position by the retaining mechanism (29);
 - 15 c) continue increasing wellbore pressure (P1) until a pressure difference between P1 and P2 exceeds a predetermined pressure difference;
 - d) open a first valve (33a) of the valve mechanism (6) to equalize pressure across the ratchet piston (27) by allowing fluid into the closed chamber (15);
 - e) decreasing the wellbore pressure (P1) to a pressure value lower than chamber
20 pressure (P2), where a pressure difference between P1 and P2 exceeds a predetermined pressure difference;
 - f) open a second valve (33b) of the valve mechanism (6) to equalize pressure across the ratchet piston (27) by releasing fluid from the closed chamber (15);
 - g) repeating steps a) to f) until the ratchet shaft (28) engages with an activation
25 pin (17) and forces the activation pin (17) from its position towards the release piston (19);

Activating the trigger assembly (3), wherein the activation of the trigger assembly (3) comprising the steps of;

5 pushing the release piston (19) with the activation pin (17) towards the first atmospheric chamber (4a), thereby increasing the pressure in the atmospheric chamber (4a);

 pushing the sliding sleeve (8) away from the at least one frack port (5) towards the second atmospheric chamber (4b) with the release piston (19);

21. The method according to claim 20, wherein in step f), the ratchet piston (27) is pushed back to its start position and the ratchet shaft (28) is retained by the retaining
10 mechanism (29);

Patentkrav

1. Tåventil (1) omfattende;
 - et hus (200) som har et indre og et ytre;
 - en glidemuffe (8);
 - en motmekanisme (2), **karakterisert ved at** motmekanismen omfatter;
 - en sylinder,
 - et skrallestempel (11, 27) med en første og andre ende, og
 - en skralleaksel (14, 28) forbundet med den andre enden,
 - en utlørsammenstilling (3) omfattende;
 - et utløserhus, og
 - et frigjøringsstempel (19), hvori
 - utlørsammenstillingen (3) er anordnet mellom motmekanismen (2) og glidemuffen (8), og hvori
 - frigjøringsstempelet (19) er konfigurert for å aktivere glidemuffen (8), og
 - skralleakselen (14, 28) er konfigurert for å aktivere frigjøringsstempelet (19), hvori tåventilen (1) ytterligere omfatter;
 - et lukket kammer (15) som omgir skralleakselen (14, 28) og er definert minst av sylindren, omfattende et kammerfluid med et kammertrykk (P2);
 - en innløpstrykkport (6) konfigurert for å være i kommunikasjon med et borehullfluid med et borehullstrykk (P1), og hvori den første enden av skrallestempelet (11, 27) er i fluidkommunikasjon med innløpstrykkporten (6), hvori skrallestempelet (11, 27) er konfigurert for å bevege seg mot utlørsammenstillingen (3) til en ny posisjon og komprimere kammerfluidet når borehullstrykket (P1) er større enn kammertrykket (P2);
 - en holdemekanisme (29) konfigurert for å holde skralleakselen (14, 28) i den nye posisjonen; og
 - en ventilmekanisme som forbinder den første og andre enden av skrallestempelet (11, 27) med hverandre, og er konfigurert for å utjevne trykket gjennom hele skrallestempelet (11, 27).
2. Tåventilen ifølge krav 1, ytterligere omfattende minst én fraktureringsport med en perforering som strekker seg fra husets (200) indre til husets (200) ytre, hvori glidemuffen (8) er anordnet for å dekke den minst ene fraktureringsporten (5).
3. Tåventilen ifølge krav 1, hvori ventilmekanismen er anordnet i skrallestempelet (11).

4. Tåventilen ifølge krav 3, hvori ventilmekanismen omfatter en ventil (16) konfigurert for å hindre fluidstrøm i en første retning fra innløpstrykkporten (6) til det lukkede kammeret (15) og å tillate fluidstrøm i en andre retning som er motsatt av den første.
5. Tåventilen ifølge krav 4, hvori ventilen (23) er en enveis avlastningsventil.
6. Tåventilen ifølge krav 4 eller 5, hvori ventilen omfatter en kule som er anordnet for å hvile på et sete.
7. Tåventilen ifølge krav 6, hvori ventilen (23) er konfigurert for å åpnes når kulen beveges bort fra setet.
8. Tåventilen ifølge krav 1, hvori ventilmekanismen omfatter en første enveisventil (33a) og en andre enveisventil (33b), der hver har én ende i fluidkommunikasjon med det lukkede kammeret (15) og en annen ende i trykkommunikasjon med innløpstrykkporten (6), hvori den første og andre enveisventilen er anordnet i motsatte retninger.
9. Tåventilen ifølge krav 1, hvori ventilmekanismen er konfigurert for å utjevne trykk i det lukkede kammeret (15) når en forhåndsbestemt differensialtrykksverdi mellom P1 og P2 er overskredet.
10. Tåventilen ifølge krav 1, hvori fluidet i det lukkede kammeret (15) er et komprimerbart fluid.
11. Tåventilen ifølge krav 1, hvori sylindere ytterligere omfatter:
et holdelement (30) konfigurert for å begrense bevegelse av skralleakselen (28) mot innløpstrykkporten (6).
12. Tåventilen ifølge krav 1, hvori sylindere ytterligere omfatter:
en holdeskulder (31) konfigurert for å begrense bevegelse av skrallestempelet (27) mot det lukkede kammeret (15).
13. Tåventilen ifølge krav 1, hvori tåventilen ytterligere omfatter:
en aktiveringsstift (17) konfigurert for å frigjøre frigjøringsstempelet (19) og et første atmosfærisk kammer (4a) anordnet mellom utløpersammenstillingen (3) og glidemuffen (8), hvori frigjøringsstempelet (19) er konfigurert for å komprimere det første atmosfæriske kammeret (4a) når det frigjøres av aktiveringsstiften (17).

14. Tåventilen ifølge krav 8, hvori den første ventilen (33a) er konfigurert for å åpnes når trykket (P1) ved innløpstrykkporten (6) har en forhåndsbestemt verdi som er større enn kammertrykket (P2) i det lukkede kammeret (15).
15. Tåventilen ifølge krav 8, hvori den andre ventilen (33b) er konfigurert for å åpnes når trykket (P1) ved innløpstrykkporten (6) har en forhåndsbestemt verdi som er mindre enn kammertrykket (P2) i det lukkede kammeret (15).
16. Tåventilen ifølge krav 1, ytterligere omfattende en trykkutjevningsskanal (23) som strekker seg fra innløpstrykkporten (6) og forbi skrallestempelsammenstillingen (12).
17. Tåventilen ifølge krav 10, hvori det komprimerbare fluidet i det lukkede kammeret (15) er silikonolje.
18. Tåventilen ifølge krav 1, ytterligere omfattende et andre atmosfærisk kammer (4b) anordnet på motsatt side av det første atmosfæriske kammeret (4a) i forhold til glidemuffen (8), hvori glidemuffen (8) er konfigurert for å bevege seg som reaksjon på trykkforskjell mellom det første atmosfæriske kammeret og det andre atmosfæriske kammeret.
19. Fremgangsmåte for å åpne en tåventil (1), **karakterisert ved at** tåventilen omfatter;
- et hus (200) som har et indre og et ytre,
 - en glidemuffe (8),
 - en tellermekanisme (2) omfattende;
 - en sylinder,
 - et skrallestempel (11) med en første og andre ende, og
 - en skralleaksel (14) forbundet med den andre enden,
 - en utlørsammenstilling (3) omfattende;
 - et utløserhus, og
 - et frigjøringsstempel (19), hvori
 - utlørsammenstillingen (3) er anordnet mellom motmekanismen (2) og glidemuffen (8), og hvori tåventilen (1) ytterligere omfatter;
 - et lukket kammer (15) som omgir skralleakselen (14) og er definert minst av sylindren, omfattende et kammerfluid med et kammertrykk (P2);
 - en innløpstrykkport (6) konfigurert for å være i kommunikasjon med et borehullfluid med et borehullstrykk (P1), og hvori den første enden av skrallestempelet (11) er i fluidkommunikasjon med innløpstrykkporten (6),

- en holdemekanisme (29), og
- en ventilmekanisme som forbinder den første og andre enden av skrallestempelet (11) med hverandre, der fremgangsmåten omfatter trinnene;
- å aktivere motmekanismen (2), hvori aktiveringen av motmekanismen omfatter trinnene;
- a) å øke borehullstrykket (P1) ved innløpstrykkporten (6) for å skyve skrallestempelet (11) mot utlørsersammenstillingen (3), hvorved skrallestempelet (11) komprimerer fluidet i det lukkede kammeret (15), og å bevege skralleakselen (14) til en ny posisjon,
- b) å holde skralleakselen i den nye posisjonen ved hjelp av holdemekanismen (29);
- c) å fortsette å øke borehullstrykket (P1);
- d) å redusere borehullstrykket (P1) til det er lavere enn kammertrykket (P2);
- e) å åpne ventilmekanismen (6) for å utjevne trykk gjennom hele skrallestempelet (11) ved å frigjøre fluid fra det lukkede kammeret (15);
- f) å gjenta trinn a) til e) inntil skralleakselen (14) går i inngrep med aktiveringsstiften (17) og tvinger en aktiveringsstift (17) fra sin posisjon mot frigjøringsstempelet (19);
- å aktivere utlørsersammenstillingen (3), hvori aktiveringen av utlørsersammenstillingen (3) omfatter trinnene;
- å skyve frigjøringsstempelet (19) med aktiveringsstiften (17) mot det første atmosfæriske kammeret (4a) og derved øke trykket i det atmosfæriske kammeret (4a);
- å skyve glidemuffen (8) bort fra den minst ene fraktureringsporten (5) mot det andre atmosfæriske kammeret (4b) med frigjøringsstempelet (19);

20. Fremgangsmåte for å åpne en tåventil (1), **karakterisert ved at** tåventilen omfatter;

- et hus (200) som har et indre og et ytre,
- en glidemuffe (8),
- en tellermekanisme (2) omfattende;
 - en sylinder,
- et skrallestempel (27) med en første og andre ende, og
- en skralleaksel (28) forbundet med den andre enden,
- en utlørsersammenstilling (3) omfattende;
 - et utløserhus, og
- et frigjøringsstempel (19), hvori
- utlørsersammenstillingen (3) er anordnet mellom motmekanismen (2) og glidemuffen (8), og hvori tåventilen (1) ytterligere omfatter;
- et lukket kammer (15) som omgir skralleakselen (28) og er definert minst av sylindren, omfattende et kammerfluid med et kammertrykk (P2),

- en innløpstrykkport (6) konfigurert for å være i kommunikasjon med et borehullfluid med et borehullstrykk (P1), og hvori den første enden av skrallestempelet (27) er i fluidkommunikasjon med innløpstrykkporten (6),

- en holdemekanisme (29), og

- en ventilmekanisme som forbinder den første og andre enden av skrallestempelet (27) med hverandre, der fremgangsmåten omfatter trinnene;

å aktivere motmekanismen (2), hvori aktiveringen av motmekanismen omfatter trinnene;

a) å øke borehullstrykket (P1) ved innløpstrykkporten (6) for å skyve skrallestempelet (27) mot utlørsammenstillingen (3), hvorved skrallestempelet (27) komprimerer fluidet i det lukkede kammeret (15), og å bevege skralleakselen (28) til en ny posisjon,

b) å holde skralleakselen (28) i den nye posisjonen ved hjelp av holdemekanismen (29);

c) å fortsette å øke borehullstrykket (P1) inntil en trykkforskjell mellom P1 og P2 overstiger en forhåndsbestemt trykkforskjell;

d) å åpne en første ventil (33a) til ventilmekanismen (6) for å utjevne trykk gjennom hele skrallestempelet (27) ved å slippe fluid inn i det lukkede kammeret (15);

e) å redusere borehullstrykket (P1) til en trykkverdi som er lavere enn kammertrykket (P2), der en trykkforskjell mellom P1 og P2 overskrider en forhåndsbestemt trykkforskjell;

f) å åpne en andre ventil (33b) til ventilmekanismen (6) for å utjevne trykk gjennom hele skrallestempelet (27) ved å frigjøre fluid fra det lukkede kammeret (15);

g) å gjenta trinn a) til f) inntil skralleakselen (28) går i inngrep med en aktiveringsstift (17) og tvinger aktiveringsstiften (17) fra sin posisjon mot frigjøringsstempelet (19);

å aktivere utlørsammenstillingen (3), hvori aktiveringen av utlørsammenstillingen (3) omfatter trinnene;

å skyve frigjøringsstempelet (19) med aktiveringsstiften (17) mot det første atmosfæriske kammeret (4a) og derved øke trykket i det atmosfæriske kammeret (4a);

å skyve glidemuffen (8) bort fra den minst ene fraktureringsporten (5) mot det andre atmosfæriske kammeret (4b) med frigjøringsstempelet (19);

21. Fremgangsmåten ifølge krav 20, hvori skrallestempelet (27) i trinn f) skyves tilbake til sin startposisjon, og skralleakselen (28) holdes av holdemekanismen (29);

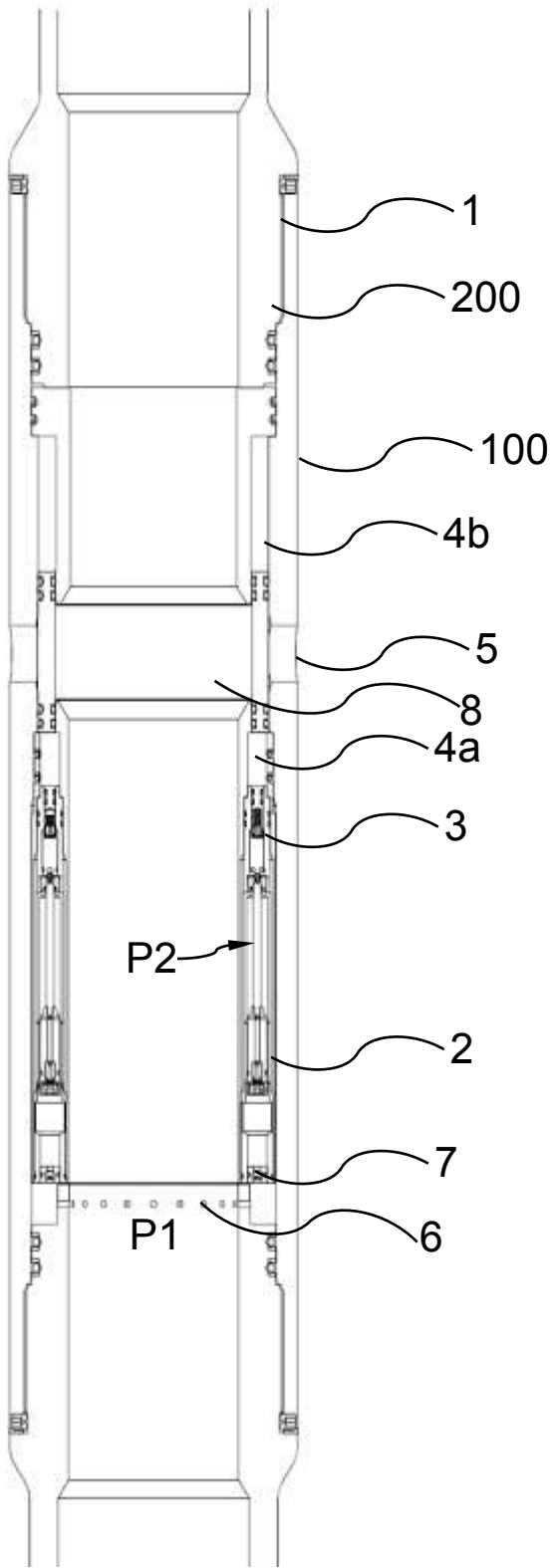

Figure 1.

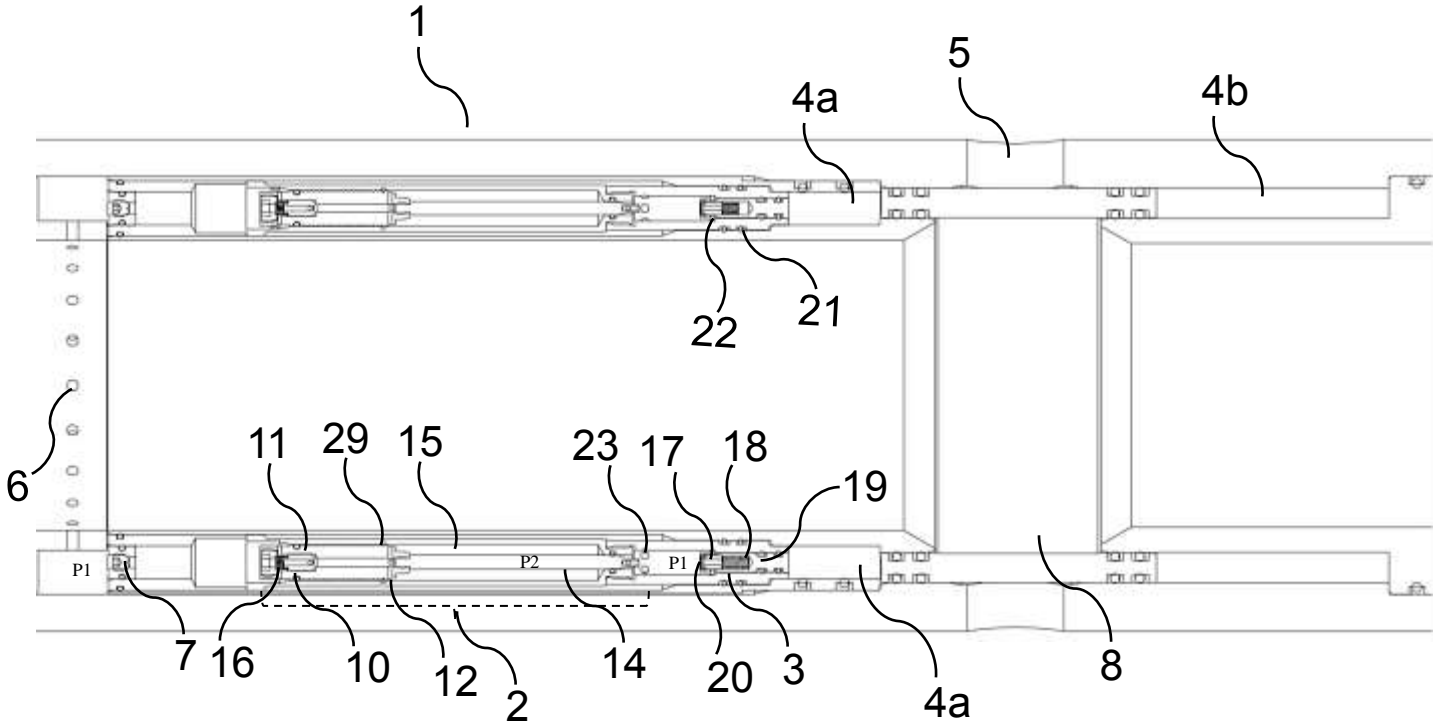

Figure 2.

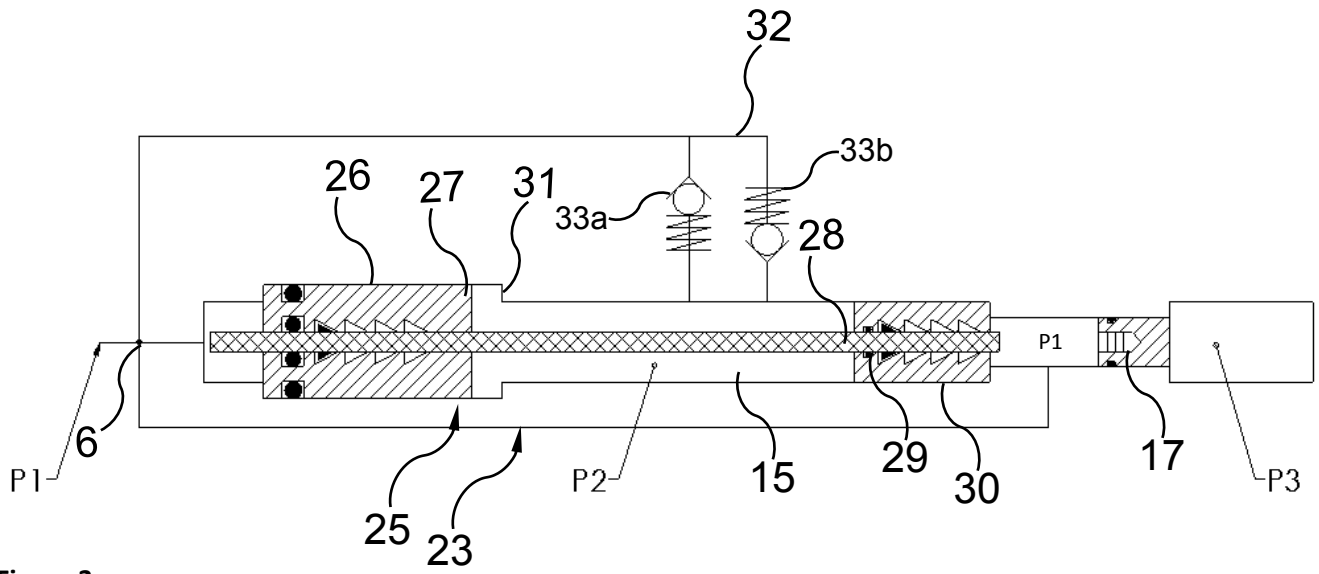

Figure 3.