



(12) PATENT

(19) NO

(11) 339568

(13) B1

NORWAY

(51) Int Cl.

A01K 61/00 (2006.01)

A01K 63/00 (2006.01)

A01K 63/02 (2006.01)

Norwegian Industrial Property Office

(21)	Application nr.	20160297	(86)	International Filing Date and Application Number	
(22)	Date of Filing	2016.02.22	(85)	Date of Entry into National Phase	
(24)	Date of Effect	2016.02.22	(30)	Priority	2015.10.09, NO, 20151360
(41)	Publicly Available	2017.01.09			
(45)	Granted	2017.01.09			
(73)	Applicant	Pure Atlantic AS, Karmøyvegen 982 B, 4250 KOPERVIK, Norge			
(72)	Inventor	Svein Johnny Naley, Karmøyvegen 982 B, 4250 KOPERVIK, Norge			
(74)	Agent or Attorney	Kåre Jostein Larsen, Gjerdefeltet, 6393 TOMREFJORD, Norge Zacco Norway AS, Postboks 2003 Vika, 0125 OSLO, Norge			

(54) Title **Offshore Fish Farming Unit**

(56) References Cited:
NO 335309 B1
SE 6165 C1
NO 332244 B1
NO 165783 B
GB 1450575 A
WO 2004055272 A2

(57) Abstract

A self-propelled offshore fish farm (1) comprises: at least one fish tank (2) with least two openings for allowing surrounding seawater to enter the fish tank (2); a propulsion means for propelling the fish farm (1)

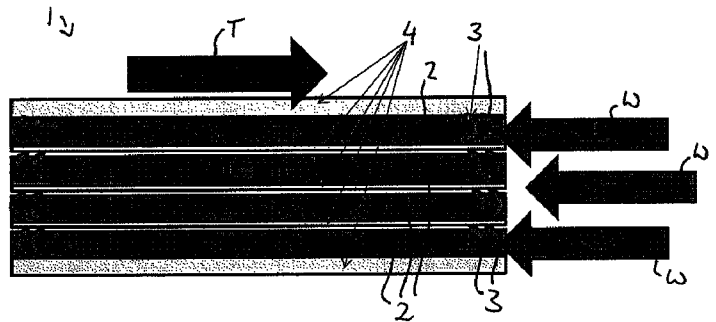

5

Offshore Fish Farming Unit

Background of the Invention

The present invention relates to fish farms. Traditionally, fish farms are often based on stationary net cages that are anchored along the coast in protected waters, as these cages are not designed to
10 handle direct impact from open water waves and weather.

A first challenge for traditional fish farming units is to ensure a constant supply of oxygen rich water. For traditional stationary farming units, the supply of enough oxygenated water will be 100% dependent on local current conditions on the location. For the majority of such farm units, the water flow through the net cages will be directly linked to the tidal cycles which again means that the flow
15 of water might be more or less zero two times per day. Another challenge is the escaping of farmed fish, often in large quantities. Such escapes and their negative impacts to the environment and cost are well documented in the fish farming industry. Additionally, local contamination and pollution underneath the stationary farms is problematic due to a build-up of fish sludge and feed residue, which is often mixed with various medication residues. This very often results in thick layers of
20 sediments on the seabed below the net cages.. Yet another problem is related to various health issues to the farmed fish. Despite heavy effort from both the farming industry, and the research community, lice and various parasite infections are still a major challenge. On top of this there are also occasional issues with large scale fish death due to lack of oxygenated water in stationary fish farms.

25 Some known offshore fish farming units are described in publications NO 335309 B1, SE 6165 C1, NO 332244 B1, NO 165783 B, GB 1450575 A, and WO 2004/055272 A2.

Hence, it is an object of the present invention to provide an improved fish farm wherein the fish are reliably supplied with oxygen rich water and wherein the negative impacts on the environment can be minimised.

30 Summary

This object is achieved by a self-propelled offshore fish farm, comprising at least one fish tank with least two openings for allowing surrounding seawater to enter the fish tank. Thus, oxygen rich water can freely flow through the fish tank, ensuring a constant supply of oxygen for the fish as well as removing any waste products from the fish tank. Additionally, a propulsion means is provided for
35 propelling the offshore fish farm so that, during the passage of the fish farm, oxygen-rich water is

- 5 forced through the fish tanks at a rate substantially proportional to the propulsion speed of the fish farm. At least one water supply channel is further provided, extending centrally along the lengthwise direction of the fish farm, wherein an inlet opening of the water supply channel is adapted to allow surrounding seawater to enter the water supply channel, and wherein the water supply channel further comprises at least one outlet opening for allowing seawater to enter at least one fish tank.
- 10 Therein, the inlet opening of the water supply channel may be provided below the waterline of the fish farm in order to reduce the risk of lice exposure, or the inlet opening of the water supply channel may extend above and below the waterline of the fish farm in order to increase inflow of seawater into the water supply channel. The water supply channel may further comprise at least one outlet opening for allowing seawater to enter at least one fish tank. Therein, a number of fish tanks may be
- 15 provided along the water supply channel, wherein the water supply channel has a separate outlet opening into each fish tank. Thus, each of these fish tanks along the water supply channel is provided with oxygenated seawater via the water supply channel.

According to some embodiments, the at least one water supply channel may extend parallel to a direction of travel of the fish farm. In other words, the at least one water supply channel may extend

20 along a longitudinal direction of the fish farm, and may e.g. extend down a centre line of the fish farm. Thus, a number of fish tanks may be provided in a row along the direction of travel of the fish farm, wherein each fish tank may be provided with an inlet opening for allowing fresh seawater from the water supply channel to enter the fish tank and with an outlet opening in the hull of the fish farm for discharging water and waste from the fish tanks. Thus, the longitudinal water supply channel

25 ensures that even fish tanks which are located in the aft portion of the fish farm are provided with fresh, oxygenated seawater. In this embodiment, it is thus not necessary that each fish tank extends along the whole length of the fish farm, so that a larger number of smaller fish tanks can be provided.

According to embodiments, the at least two openings may be arranged such that the flow of

30 seawater through the at least one fish tank is controllable by adjusting the speed at which the fish farm is propelled through water. Hence, compared to stationary fish farms, a constant supply of oxygenated water can be ensured independently of local current conditions by adjusting the propulsion speed of the fish farm.

According to embodiments, the at least one fish tank may be open at its respective front and rear

35 ends. Thus, the openings for allowing seawater to flow through the fish tank may be maximized while providing a very simple and cost-effective structure of the at least one fish tank.

5 According to embodiments, two independent escape barriers may be provided at the at least two openings in the at least one fish tank for preventing fish from passing through the openings. Thus, the escape of fish from the fish farm can be reliably prevented. The escape barrier may be formed as respective gates which may comprise mesh or grid sections. Two identical gates may be provided next to each other, wherein the gates may be individually opened and closed. The escape barriers
10 may be manufactured from steel or composite material and may comprise a steel structure that can withstand the forces from the fish and water flow. According to some embodiments, the part of the gate that is preventing the fish from escaping may consist of a combination of a composite or metal mesh in combination with traditional net cage material.

According to embodiments, the propulsion means may comprise at least one wind turbine. Thus, the
15 fish farm may be independent of fossil fuels and the emissions of the fish farm are minimized.

Therein, the at least one wind turbine may provide direct propulsion of the fish farm and/or power generation for electric motors for propulsion of the fish farm. According to embodiments, the wind turbines may also be designed for combined direct propulsion and power generation. The wind turbines may be of vertical or axial type. Forward motion of the vessel might be additionally
20 supported by traditional sail and or maritime kite solutions. Alternatively, the vessel may be propelled only by modern sail technology or maritime kites. In all cases, backup propulsion may be provided by diesel or gas generators which may drive a conventional propeller system.

According to embodiments, the fish farm may further comprise a baleen gate provided at a front portion of the fish farm. Thus, the forces applied by incoming waves can be deflected and scattered
25 by the baleen gate in order to avoid damage to the fish tanks and provide a more uniform flow through the fish tanks.

Therein, the baleen gate may comprise a steel grid construction for deflecting floating obstacles from the fish farm and for partly removing the energy of the waves hitting the bow of the fish farm.

30 According to some embodiments, one, two or more water supply channels may be provided, with a longitudinal division between adjacent water supply channels. For example, two water supply channels may be provided on either side of a central longitudinal division. Therein, each water supply channel may supply water to multiple fish tanks. For a particularly simple construction of the fish farm, each fish tank may be served only by a single water supply channel, so that e.g. two water
35 supply channels which are provided on either side of a central longitudinal division may each serve the fish tanks located along one side of the fish farm. Alternatively, for improving the flow through

5 the fish tanks, at least some fish tanks may be served by multiple water supply channels, so that inflow of oxygenated seawater into these fish tanks is provided through more than one water supply channel.

According to some embodiments, an inlet opening of at least one fish tank may be connected to the at least one water supply channel, and an inlet opening of at least one other fish tank may directly
10 open to an outside surface of the fish farm. Hence, the inflow of oxygenated seawater into some of the fish tanks may not be provided by the water supply channel, but may instead be provided via their own inlet opening in the hull of the fish farm. For example, fish tanks located at the front of the fish farm may be provided with their own inlet openings in the bow of the fish farm, while fish tanks located behind these front fish tanks may be served by the at least one water supply channel.

15 According to some embodiments, the inlet opening of the at least one water supply channel may be provided with a baleen gate for deflecting floating obstacles from the fish farm and for partly removing the energy of the waves hitting the bow of the fish farm.

According to some embodiments, divisions may be provided between adjacent fish tanks, and wherein hollow spaces may be formed inside the divisions. These hollow spaces may be adapted to
20 be filled with ballast material and/or with technical installations. Thus, the overall stability of the fish farm can be improved by providing ballast at suitable positions, and spaces for running pipes, cabling and the like are provided between the fish tanks, without decreasing the production volume of the fish farm.

According to some embodiments, the fish farm may comprise a double bottom, and hollow spaces
25 may be formed in the double bottom. These hollow spaces may be adapted to be filled with ballast material and/or with technical installations. Thus, further usable space for stabilizing and for running technical installations e.g. to and from the fish farm's propellers is provided in the double bottom, which further serves to increase the strength of the fish farm's hull.

Brief description of the Drawings

30 Embodiments of the invention will now be described with reference to the drawings, in which like reference numerals denote the same or corresponding elements, and in which:

Fig. 1 shows a schematic diagram of a fish farm according to an embodiment;

Fig. 2 shows a top view of the fish tanks in a fish farm according to a first embodiment;

Fig. 3 shows a sectional view of the fish tanks of Fig. 2;

35 Fig. 4 shows a view of the main deck of a fish farm that may be provided in conjunction with any of the other embodiments;

- 5 Fig. 5 shows a sectional view below the main deck of the fish farm according to the first embodiment;
- Fig. 6 shows a sectional view of a fish farm according to the first embodiment;
- Fig. 7 shows a sectional view through the fish tanks in a midship region of a fish farm according to the first embodiment;
- 10 Fig. 8 shows a midship sectional view through the fish tanks as shown in Fig. 7 with a fish gate;
- Fig. 9 shows a front view of a fish farm according to the first embodiment with baleen gates;
- Fig. 10 shows a side view of a fish farm according to the first embodiment;
- Fig. 11 shows a second embodiment of a fish farm;
- Fig. 12 shows a third embodiment of a fish farm;
- 15 Fig. 13 shows a front view of the fish farm of the third embodiment;
- Fig. 14 shows a front view of a fish farm according to a modification of the third embodiment;
- Fig. 15 shows an example of a main deck that may be used in conjunction with the fish farm of any embodiment;
- Fig. 16 shows a first example of an internal layout of fish tanks for the fish farm according to the
- 20 third embodiment;
- Fig. 17 shows a second example of an internal layout of fish tanks for the fish farm according to the third embodiment; and
- Fig. 18 shows a midship sectional view of the fish tanks along line A-A as shown either in Fig. 16 or in Fig. 17.

25 Detailed description

In the following description of various embodiments, reference will be made to the drawings, in which like reference numerals denote the same or corresponding elements. The drawings are not necessarily to scale. Instead, certain features may be shown exaggerated in scale or in a somewhat simplified or schematic manner, wherein certain conventional elements may have been left out in

30 the interest of exemplifying the principles of the invention rather than cluttering the drawings with details that do not contribute to the understanding of these principles.

It should be noted that, unless otherwise stated, different features or elements may be combined with each other whether or not they have been described together as part of the same embodiment below. The combination of features or elements in the exemplary embodiments are done in order to

35 facilitate understanding of the invention rather than limit its scope to a limited set of embodiments, and to the extent that alternative elements with substantially the same functionality are shown in respective embodiments, they are intended to be interchangeable, but for the sake of brevity, no attempt has been made to disclose a complete description of all possible permutations of features.

5 Furthermore, those with skill in the art will understand that the invention may be practiced without many of the details included in this detailed description. Conversely, some well-known structures or functions may not be shown or described in detail, in order to avoid unnecessarily obscuring the relevant description of the various implementations. The terminology used in the description presented below is intended to be interpreted in its broadest reasonable manner, even though it is
10 being used in conjunction with a detailed description of certain specific implementations of the invention.

Reference is first made to Fig. 1 which shows a first embodiment of a fish farm 1 that is constructed as an ocean going barge with propulsion. The propulsion moves the barge in a direction of travel as indicated by the arrow "T" in Fig. 1. According to this embodiment, the barge 1 is divided into a
15 number of longitudinal fish tanks 2 that are open to the sea at both front and rear ends so that seawater can flow through the fish tanks 2 in the direction indicated by the arrows "W". On each end of the longitudinal tanks 2, a pair of barriers 3 is provided, wherein seawater can flow through the barriers 3, but the fish will be stopped. For additional security against fish escaping, two independent barriers 3 may be provided at either end of each fish tank 2. The barge further has a number of
20 longitudinal divisions 4 between the fish farm tanks for stability, ballast, and various technical installations.

Hence, in the fish farm 1 as shown in Fig. 1, the fish tanks 2 are open in the front and at the back and circulation of water through the fish tanks 2 is created by pushing the tanks 2 (and the vessel 1) through the water. There is no need for any mechanical pumping etc. in order to ensure a constant
25 supply of oxygenated water to the fish and the present fish farm 1 does not need to rely on local tides and currents, which generally slow down or even stop for at least some time during the course of a day.

Fig. 2 shows a top view of the tanks 2 according to the first embodiment, wherein three propellers 5 for propulsion of the barge 1 are provided in a rear part between and adjacent to respective fish
30 tanks. As indicated in the cutout section of Fig. 2, water scoop openings 6, which may be provided with mesh gates in order to prevent fish escaping therethrough, may be provided in a bottom wall of the respective fish tanks 2. In some or all of the longitudinal divisions 4, hollow spaces 7 may be provided, which may be kept void or may be filled with ballast material for additional stability of the fish farm 1. As shown in Fig. 3, the barge may comprise a double bottom below the fish tanks 2,
35 wherein additional ballast tanks 8 and technical installations 9 such as e.g. pumps, pipes and the like may be provided.

5 As shown in Fig. 4, the barge 1 is equipped with a main deck 10 above the fish tanks 2. According to the embodiment of Fig. 4, a superstructure generally indicated as 11 is provided that will contain cabins and facilities for the crew, bridge, helicopter deck, workshops, control room for farm, storage of fish feed, fuel tanks for backup power, a number of wind turbines for propulsion and power generation, fish processing and cold storage facilities. The main deck 10 as shown in Fig. 4 can be
10 provided with a barge 1 according to any of the embodiments described herein.

Fig. 5 shows a sectional view of the barge 1 according to the first embodiment below the main deck 10, showing the fish tanks 2 with double fish gate barriers 3 at either end of each fish tank 2. As shown in the cutout portion in Fig. 5, the side walls of the outer fish tanks 2 may be fitted with water scoops 6 for providing an additional supply of oxygenated seawater. The scoops 6 are optional
15 features, and the barge 1 according to the first embodiment may be modified such that no scoops 6 are present. If scoops 6 are installed, they might be fixed or they might have adjustable openings.

These scoops 6, as well as any scoops 6 provided on the bottom wall of the fish tanks 2 (see Fig. 2 and 3), may comprise openings which are shaped such that seawater is forced into or out of the fish tanks when the hull of the vessel 1 is propelled through the water. Alternatively or additionally, the
20 scoops may comprise funnels or similar structures for directing water flow into and/or out of the fish tanks 2 and there may be flaps or similar means for partially closing the scoops 6 in order to control the flow of seawater into and out of the fish tanks 2 according to current, speed of the barge 1 and local conditions. Additionally, the scoop openings are provided with mesh covers or similar fish
25 barriers that prevent fish from escaping through the scoops 6. Therein, large scoops 6 may preferably be provided in the aft portion of the barge 1 in order to provide more oxygenated water in the aft part of the fish tanks 2 if necessary.

In the front of the vessel 1, as indicated in Fig. 5, a steel grid structure may be provided which acts as a baleen gate 12 (see Fig. 9) for splitting incoming waves and for deflecting objects that might otherwise hit the fish gates 3 at the front of the fish tanks 2. This structure resembles the baleen
30 plates used by baleen whales to filter food from the water. Thus, it can be ensured that the flow speed and direction through the fish tanks 2 is not adversely affected by incoming waves but instead remains substantially uniform and proportional to the barge's propulsion speed while the baleen gate 12 takes the energy out of the large waves at the same time as it allows oxygenated water to flow freely into the farming tanks.

35 The side sectional view of Fig. 6 illustrates the double bottom of the barge 1 according to the first embodiment, wherein hollow spaces 7 (see the cross sectional views in Figs 7 and 8) are provided similar to the hollow spaces in the double side walls as shown in Fig. 2. The hollow spaces 7 may

5 contain ballast tanks and technical installations. The double bottom containing ballast tanks and technical installations may be provided in conjunction with the fish tanks according to any one of the embodiments described herein.

Fig. 7 to 9 show respective views of the fish tanks 2, wherein the cross sectional views of Fig. 7 and 8 are located roughly at a midship area of the barge 1 and show the fish tanks 2 without and with a fish barrier gate 3 in place. The front view of Fig. 9 shows the baleen gate 12 in the bow of the vessel 1.

Fig. 10 shows a side view of the first embodiment of the fish farm 1, wherein the main propulsion is performed by means of a number of wind turbines 13 specially designed for combined direct propulsion and power generation. Alternative propulsion and steering power may come from a number of conventional propellers driven by electric motors, such as the propellers 5. The power to run the electric motors can be taken directly from the wind turbines 13, or if necessary supplement power from conventional generators and or battery banks may be provided for energy storage during periods with low wind. Therein, an electric motor driving the propellers 5 could be electrically directly connected to the generator on the wind turbine. Alternatively, the electric motor driving the propellers 5 could be connected to a common switchboard. The switchboard will receive its power from the wind turbines 13 and/or from traditional generators running on fossil fuels. In parallel with this, a large battery bank could be added that would then act as a buffer to compensate for the difference in demand from the propeller motors and the variations in power generated by the wind turbines 13.

The wind turbines 13 may be rotatable so that the barge 1 can travel in any direction relative to the wind while keeping the rotors of the wind turbines 13 at an advantageous orientation relative to the wind direction. Additionally, it will generally not be necessary for the fish farm 1 to follow a set route with a predetermined velocity, but instead the hull of the fish farm 1 generally just needs to be pushed through the water at a sufficient speed for obtaining water flow through the fish tanks 2. Thus, the route and velocity of the vessel 1 can be selected according to wind direction and conditions.

In the first embodiment as shown in Fig. 1-10, the vessel 1 comprises four longitudinal fish tanks 2, the total length of the vessel 1 may range from 200 m to about 600 m, the beam is about 100 m, and the depth to main deck 10 is 50 m. The design draught may be 40 m and the light ship draught may be 1.5 m. With such an exemplary fish farm 1, a production volume of about 940 000 m³ may be achieved. The number of tanks, overall size etc are just indicative and may be adjusted.

According to a second embodiment as shown in Fig. 11, the fish tanks 2 are aligned at an angle to the direction T of travel of the fish farm 1. Respective escape barriers 3 and baleen gates 12 are provided

5 at the openings of the diagonally extending fish tanks 2. Since this reduces the overall length of each fish tank 2 between a water inlet and a water outlet opening, the diagonal fish tank alignment serves to reduce the problem of oxygen depletion as the water moves towards the stern end in the respective fish tank 2. Additionally, the diagonal arrangement allows dividing the usable space in the fish farm 1 into a larger number of fish tanks 2. This may be advantageous in terms of housing fish of
10 varying age, and in terms of size and capacity of the receiving facility, and the overall capacity/volume of the fish tanks may be increased from about 940 000 m³ as in the first embodiment discussed above to about 1 300 000 m³.

The diagonal arrangement of fish tanks 2 in the second embodiment may result in the vessel 1 being drawn to one side as fresh water is drawn into each consecutive tank in a diagonal direction which
15 includes a sideways component. However, since the speed of the fish farm 1 is generally low, this only poses small problems in terms of navigation. Additionally, with the diagonal fish tank arrangement, the ship may catch more waves from one side. This problem can be mitigated by a design and structural modification at the top deck 10.

Fig. 12 shows a fish farm 1 according to a third embodiment. Therein, the main deck 10 is provided
20 with a wind turbine 13 as described above on conjunction with Fig. 10. Additionally to or instead of the wind turbine 13, one or more sails 14 may be provided so that modern sail technology may be used as an auxiliary or as a main propulsion mechanism for the fish farm 1. As a further modification, multiple wind turbines 13 may be provided, or kites may be used for propelling the fish farm 1. In the fish farm 1 according to the third embodiment, a number of baleen gates 12 may be provided at the
25 front and side surfaces of the hull. Alternatively, baleen gates 12 may be provided only at the bow of the hull and fish barriers which allow seawater to pass but which stop fish from passing through may be provided at the sides of the hull.

The dimensions of the fish farm 1 according to the third embodiment may be similar to the dimensions given above for the fish farm 1 according to the first embodiment.

30 As indicated in the front view of Fig. 13, baleen gates 12 at the bow of the vessel 1 may extend above the waterline in order to increase the inflow of water into the fish tanks 2 (see below). Alternatively, as shown in Fig. 14, baleen gates 12 may be provided below the waterline, which reduces the risk of lice exposure.

Fig. 15 shows an example of facilities that may be provided on the main deck 10 of the fish farm 1
35 according to any embodiment. Therein, sails 14 for propulsion are provided on the main deck 10, as well as two separate cold store facilities 15, a fish slaughtering facility 16 as well as a processing facility 17, a workshop 18 and a lab 19. The aft of the vessel 1 as shown in Fig. 15 is designed as

5 explained in detail below in conjunction with Fig. 17. However, the structures and layout of the main deck 10 as shown in Fig. 15 may also be provided in conjunction with the vessel wherein the aft section is designed such as e.g. shown in Fig. 4.

As shown in Fig. 16, the layout of the fish tanks 2 of the third embodiment differs from the layout of the fish tanks 2 according to the first and second embodiments mainly by the provision of at least
10 one water supply channel 20 that extends along the lengthwise direction of the vessel 1. The water supply channel 20 serves to provide an inflow of fresh, oxygenated water to a number of separate fish tanks 2 which are provided in a row along each water supply channel 20. In the example shown in Fig. 16, two water supply channels 20 are provided adjacent to one another, with a longitudinal division 21 between the water supply channels 20. At the bow of the vessel 1, water enters into the
15 respective water supply channels 20 through corresponding baleen gates 12. Therein, as shown in Fig. 13 and 14, the position and size of the baleen gates 12 and the associated water inlet opening can be adjusted based on the requirements, i.e. either in order to maximise the water flow (see Fig. 13) with baleen gates 12 extending above and below the waterline, or in order to minimise lice exposure (see Fig. 14) with baleen gates 12 and corresponding inflow openings being provided below
20 the waterline.

In addition to the water inflow via the one or more water supply channels 20, some or all of the fish tanks 2 of the fish farm 1 according to the third embodiment may be provided with their own water inlet openings, which may also be provided with baleen gates 12. In the example shown in Fig. 16, the fish tanks 2 located at the bow of the vessel are provided with their own water inlet openings,
25 while the water supply channels 20 provide fresh oxygenated water to all other fish tanks 2 which are located further along the longitudinal direction of the vessel 1.

Between adjacent fish tanks 2, divisions 4 may be provided. Hollow spaces 7 in the respective divisions 4 may be filled with ballast for stability or may be used to house various technical installations. In the example shown in Fig. 16, an additional hollow space 7 is provided at the aft of
30 the vessel, which may accommodate propellers or technical installations.

Fig. 17 shows an alternative layout of the fish farm 1 according to the third embodiment. Therein, the aft of the vessel 1 differs from the aft of the vessel 1 as shown in Fig. 16. Thus, in the layout as shown in Fig. 17 the rear fish tanks 2 located in the aft region are larger than the fish tanks 2 in the aft of the vessel 1 of Fig. 16. Hence, the layout of Fig. 17 provides a slight increase in the overall
35 capacity/volume of the fish tanks when compared to the layout of Fig. 16, at the expense of providing less usable, hollow space 7 in the aft of the vessel 1 for placing propellers, technical installations and the like.

5 The water inlet and exit openings of each fish tank 2 as shown in either Fig. 16 or Fig. 17 may be provided with barriers 3 or double barriers 3 as discussed in conjunction with the first embodiment, wherein seawater can flow through the barriers 3, but the fish will be stopped.

In the midship sectional view of Fig. 18, an example embodiment is shown wherein the hollow spaces 7 provided in the respective longitudinal divisions 4 between the water supply channels 20 and the
10 respective fish tanks 2 have been filled with ballast material for added stability of the vessel 1. In other embodiments, only some of the hollow spaces 7 in some of the divisions 4 may be filled with ballast, while pipes, electrical cables and other technical installations may be provided in other hollow spaces 7. As further shown in Fig. 18, the hollow space 7 in the bottom of the vessel 1 has not
15 been filled and can thus be used for housing technical installations, pipes, cables and the like.

According to further embodiments, ballast material may also be provided in the hollow spaces 7 formed in the bottom of the vessel.

Thus, the third embodiment provides similar advantages to the second embodiment discussed above, wherein the short overall length of each fish tank 2 between a water inlet and a water outlet opening reduces the problem of oxygen depletion as the water flows through each fish tank 2, while
20 the usable space in the fish farm 1 is divided into a larger number of fish tanks 2 which allows the simultaneous housing of fish of varying ages. At the same time, the fish farm 1 of the third embodiment avoids the disadvantages of the second embodiment discussed above, since water flow through the vessel 1 is provided in a symmetrical manner with the inflow along the direction of travel of the vessel and the outflow of sludge from the fish tanks 2 provided at both sides of the vessel 1,
25 with the axis of symmetry along the direction of travel of the vessel.

For all embodiments described above, in controlling the speed and direction of travel of the fish farm 1, the location of the barge may be based on the optimum growth conditions for the farmed fish. The following parameters can be used in order to make these decisions:

- historical and actual data for water temperature;
- 30 – historical and actual data for water oxygen level;
- historical and actual data for concentration of lice.

In summary, the various embodiments of the fish farm 1 described above constitute a fully mobile concept that gives full control to water flow and oxygen levels by regulating the speed through water and the global position of the unit. With the mobile farm unit 1, the sludge from the fish will be
35 dispersed in open waters without any risk of local sediment and sludge buildups. The mobile fish farm removes the fish from coastal areas. Scientific research has proven that the concentration of lice and parasites are particular high along the coast lines especially during summer with high water

5 temperatures. It has also been found that the concentration of lice is much higher close to the surface compared to water lower down. Thus, with controlling the fish farm 1 such that it travels further away from coastal areas during the times with higher lice infestation, the parasite load of the fish can be minimized.

The fish farm 1 as described above is intended for worldwide fish farming. For existing fish farming
10 communities, it can be used to increase productivity and reduce the disease exposure of fish compared to stationary fish farms. Hence, the fish farm 1 can be used to increase the production capacity by utilizing an individual country's territorial waters instead of only limiting production to coastal regions.

According to an aspect, the fish farm 1 according to embodiments provides a controlled flow of
15 oxygenated water through the farm by the means of adjusting the speed of the farm through water. Therein, controlling the oxygen level in the water may be achieved by the means of global re-location of the farm 1. Local accumulation of fish sewage and feed residue may be avoided by moving the farm offshore into open waters and thus the health conditions for the farmed fish may be improved by being able to move the farm away from coastal areas during time periods with increased lice and
20 parasite exposure.

With water inlet openings 6 provided at the lower portions of the vessel's hull such as e.g. in the bottom wall of the fish tanks 2, the exposure to lice may further be reduced by being able to supply non surface water to the farm 1 by adjusting the water inlet openings and the global location of the unit.

25 The baleen gate construction 12 in the bow of the vessel 1 protects the fish tanks 2 against damage from floating obstacles, such as shipping containers, and further serves to partly remove the energy in the waves hitting the bow and thus to keep a substantially uniform water flow into and through the fish tanks 2. Improved protection against fish escapes may be achieved by adding a second escape barrier 3 that might be made of steel or composite material.

30 The provision of longitudinal water supply channels 20 allows the division of the fish farm into a larger number of smaller fish tanks 2, wherein it is not necessary that each fish tanks extends along a direction of travel of the vessel 1 and is provided with an inlet opening in the bow of the vessel 1. Instead, the water supply channels 20 may transport fresh, oxygenated seawater along the inside of the vessel 1, and fish tanks 2 may be positioned in a row along each water supply channel 20. Thus,
35 inflow of fresh oxygenated sweater can be ensured even for fish tanks located at the aft portion of the vessel 1.

5 Claims

1. Self-propelled offshore fish farm (1), comprising:
at least one fish tank (2) with least two openings for allowing surrounding seawater to enter the fish tank (2); and
a propulsion means (13) for propelling the fish farm (1), **characterised in that** the self-propelled offshore fish farm (1) further comprises at least one water supply channel (20) extending centrally along the lengthwise direction of the fish farm (1), wherein an inlet opening of the water supply channel (20) is adapted to allow surrounding seawater to enter the water supply channel (20), and wherein the water supply channel (20) further comprises at least one outlet opening for allowing seawater to enter at least one fish tank (2).
10
2. Self-propelled offshore fish farm (1) according to claim 1, wherein the at least two openings are arranged such that the flow of seawater through the at least one fish tank (2) is controllable by adjusting the speed at which the fish farm (1) is propelled through water.
15
3. Self-propelled offshore fish farm (1) according to any one of claims 1 or 2, wherein the at least one fish tank (2) is open at its respective front and rear ends.
20
4. Self-propelled offshore fish farm (1) according to any one of claims 1 to 3, wherein two independent escape barriers (3) are provided at the at least two openings in the at least one fish tank (2) for preventing fish from passing through the openings.
25
5. Self-propelled offshore fish farm according to any one of claims 1 to 4, wherein the propulsion means (13) comprises at least one wind turbine (13).
30
6. Self-propelled offshore fish farm (1) according to claim 5, wherein the at least one wind turbine (13) provides direct propulsion of the fish farm (1) and/or power generation for electric motors for propulsion of the fish farm (1).
35
7. Self-propelled offshore fish farm (1) according to any one of claims 1 to 6, further comprising a baleen gate (12) provided at the bow of the fish farm (1).
35
8. Self-propelled offshore fish farm (1) according to claim 7, wherein the baleen gate (12) comprises a steel grid construction for deflecting floating obstacles from the fish farm (1) and for partly removing the energy of the waves hitting the bow of the fish farm (1).

5

9. Self-propelled offshore fish farm (1) according to any one of claims 1-8, wherein two or more water supply channels (20) are provided, with a longitudinal division (21) between adjacent water supply channels (20), and wherein each water supply channel (20) supplies water to multiple fish tanks (2).

10

10. Self-propelled offshore fish farm (1) according to any one of claims 1 to 9, wherein an inlet opening of at least one fish tank (2) is connected to the at least one water supply channel (20), and wherein an inlet opening of at least one other fish tank (2) directly opens to an outside surface of the fish farm (1).

15

11. Self-propelled offshore fish farm (1) according to any one of claims 1 to 10, wherein the inlet opening of the at least one water supply channel (20) is provided with a baleen gate (12).

20

12. Self-propelled offshore fish farm (1) according to any one of claims 1 to 11, wherein divisions (4) are provided between adjacent fish tanks (2), and wherein hollow spaces (7) are formed inside the divisions (4), which hollow spaces (7) are adapted to be filled with ballast material and/or with technical installations.

25

13. Self-propelled offshore fish farm (1) according to any one of claims 1 to 12, wherein the fish farm (1) comprises a double bottom, and wherein hollow spaces (7) formed in the double bottom are adapted to be filled with ballast material and/or with technical installations.

Patentkrav

1. Selvdrevet offshore fiskeoppdrettsanlegg (1) omfattende:
minst én fisketank (2) med minst to åpninger for å tillate at omgivende
5 sjøvann går inn i fisketanken (2); og
et fremdriftsmiddel (13) for å drive fiskeoppdrettsanlegget (1),
karakterisert ved at det selvdrevne offshore fiskeoppdrettsanlegget (1)
ytterligere omfatter minst én vanntilførselskanal (20), som strekker seg sentralt
langs fiskeoppdrettsanlegget, hvori en innløpsåpning til vanntilførselskanalen
10 (20) er tilpasset til å tillate at omgivende sjøvann går inn i vanntilførselskanalen
(20), og hvori vanntilførselskanalen (20) ytterligere omfatter minst én
utløpsåpning for å tillate at sjøvann går inn i minst én fisketank (2).

2. Selvdrevet offshore fiskeoppdrettsanlegg (1) ifølge krav 1, hvori de minst
15 to åpningene er anordnet slik at strømmen av sjøvann gjennom den minst ene
fisketanken (2) kan styres ved å justere hastigheten til fiskeoppdrettsanlegget
(1) gjennom vannet.

3. Selvdrevet offshore fiskeoppdrettsanlegg (1) ifølge et hvilket som helst av
20 kravene 1 eller 2, hvori den minst ene fisketanken (2) er åpen i sin respektive
fremre og bakre ende.

4. Selvdrevet offshore fiskeoppdrettsanlegg (1) ifølge et hvilket som helst av
25 kravene 1 til 3, hvori to uavhengige rømningsbarrierer (3) er tilveiebrakt i de
minst to åpningene i den minst ene fisketanken (2) for å hindre at fisk passerer
gjennom åpningene.

5. Selvdrevet offshore fiskeoppdrettsanlegg ifølge et hvilket som helst av
30 kravene 1 til 4, hvori fremdriftsmiddelet (13) omfatter minst én vindturbin (13).

6. Selvdrevet offshore fiskeoppdrettsanlegg (1) ifølge krav 5, hvori den
minst ene vindturbinen (13) tilveiebringer direkte fremdrift av
fiskeoppdrettsanlegget (1) og/eller kraftgenerering for elektriske motorer for
35 fremdrift av fiskeoppdrettsanlegget (1).

7. Selvdrevet offshore fiskeoppdrettsanlegg (1) ifølge et hvilket som helst av kravene 1 til 6, ytterligere omfattende en bardeport (12) tilveiebrakt i fiskeoppdrettsanleggets (1) baug.

5

8. Selvdrevet offshore fiskeoppdrettsanlegg (1) ifølge krav 7, hvori bardeporten (12) omfatter en stålgitterkonstruksjon for å avbøye flytende hindringer fra fiskeoppdrettsanlegget (1) og for delvis å fjerne energien til bølgene som treffer baugen til fiskeoppdrettsanlegget (1).

10

9. Selvdrevet offshore fiskeoppdrettsanlegg (1) ifølge et hvilket som helst av kravene 1-8, hvori to eller flere vanntilførselskanaler (20) er tilveiebrakt, med et langsgående skille (21) mellom tilstøtende vanntilførselskanaler (20), og hvori hver vanntilførselskanal (20) tilfører vann til flere fisketanker (2).

15

10. Selvdrevet offshore fiskeoppdrettsanlegg (1) ifølge et hvilket som helst av kravene 1 til 9, hvori en innløpsåpning til minst én fisketank (2) er forbundet med den minst ene vanntilførselskanalen (20), og hvori en innløpsåpning til minst én annen fisketank (2) åpner seg direkte mot en utvendig overflate til fiskeoppdrettsanlegget (1).

20

11. Selvdrevet offshore fiskeoppdrettsanlegg (1) ifølge et hvilket som helst av kravene 1 til 10, hvori innløpsåpningen til den minst ene vanntilførselskanalen (20) er tilveiebrakt med en bardeport (12).

25

12. Selvdrevet offshore fiskeoppdrettsanlegg (1) ifølge et hvilket som helst av kravene 1 til 11, hvori skiller (4) er tilveiebrakt mellom tilstøtende fisketanker (2), og hvori hule rom (7) er dannet inni skillene (4), hvilke hule rom (7) er tilpasset til å fylles med ballastmateriale og/eller med tekniske installasjoner.

30

13. Selvdrevet offshore fiskeoppdrettsanlegg (1) ifølge et hvilket som helst av kravene 1 til 12, hvori fiskeoppdrettsanlegget (1) omfatter en dobbel bunn, og hvori hule rom (7) dannet i den doble bunnen er tilpasset til å fylles med ballastmateriale og/eller med tekniske installasjoner.

35

1/7

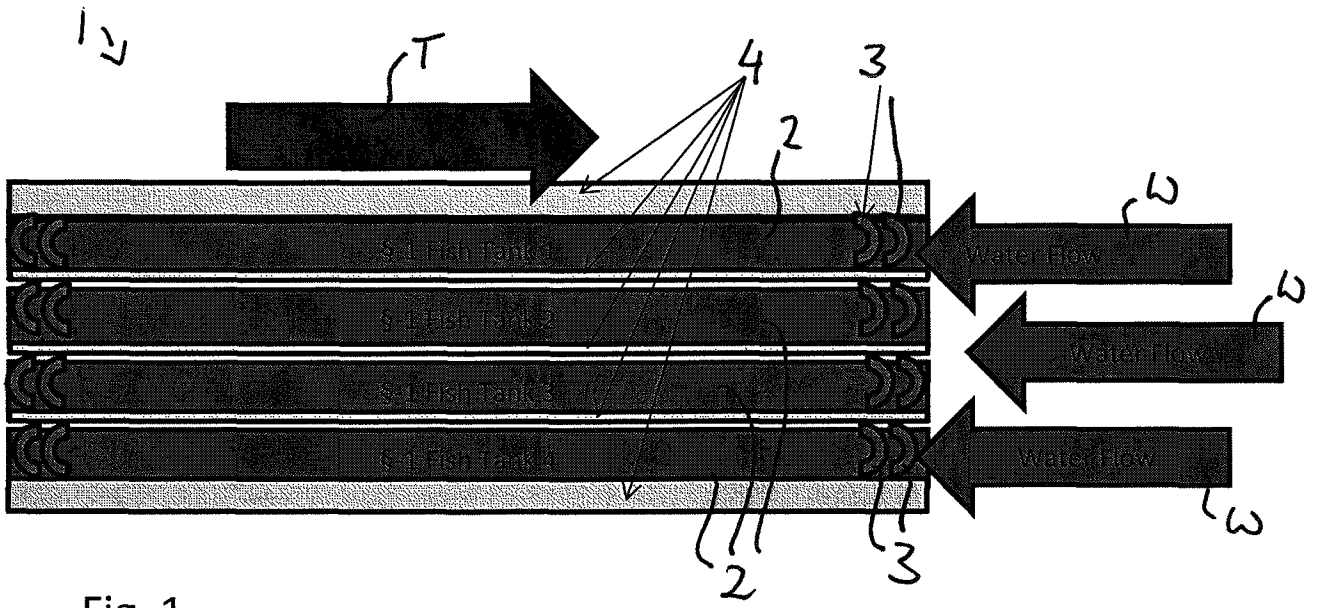

Fig. 1

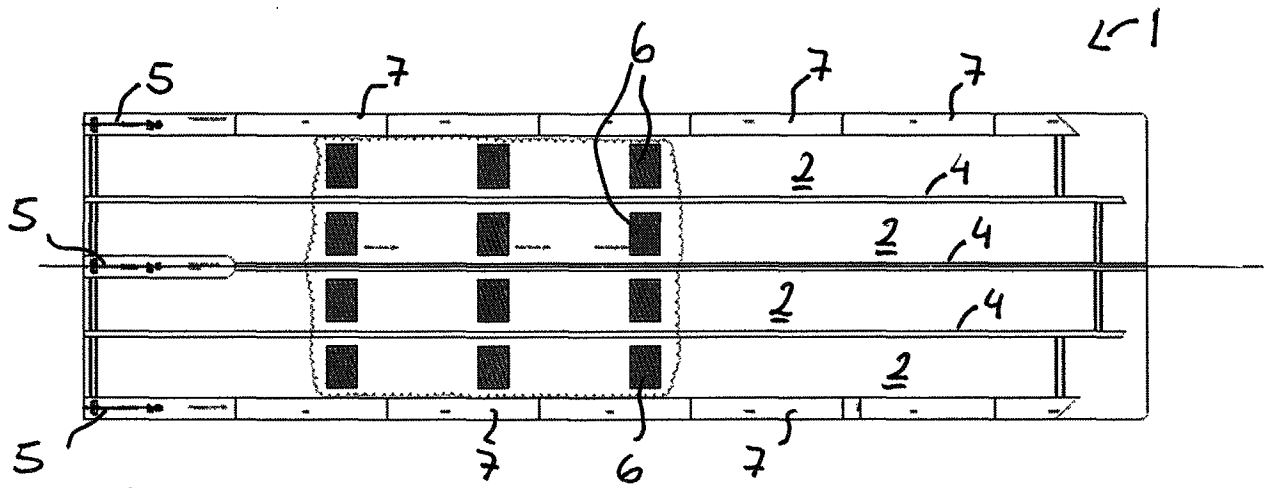

Fig. 2

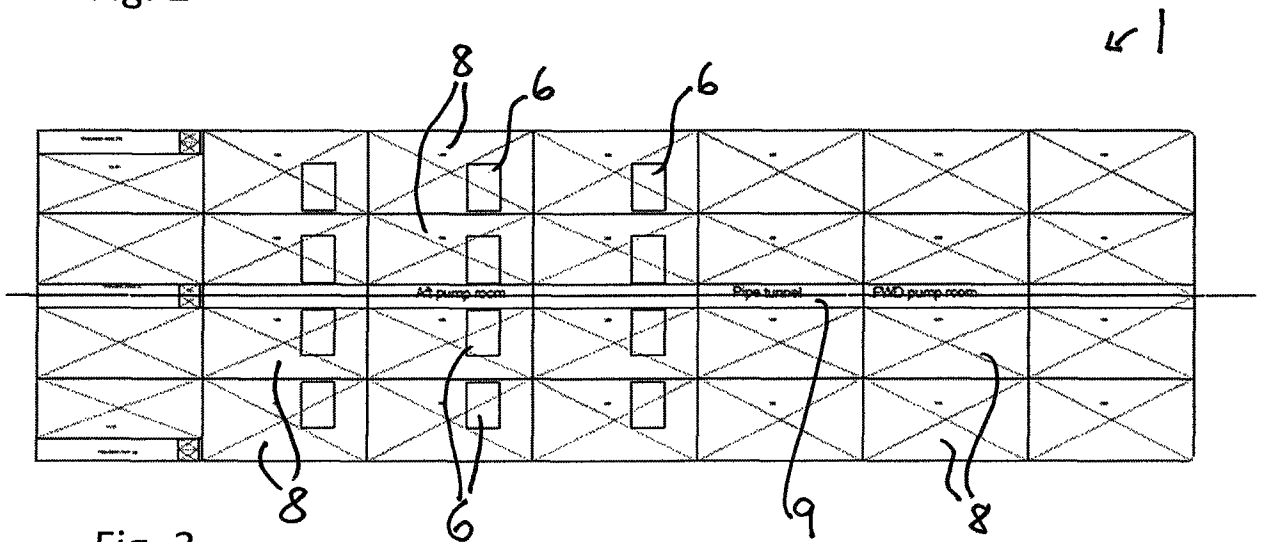

Fig. 3

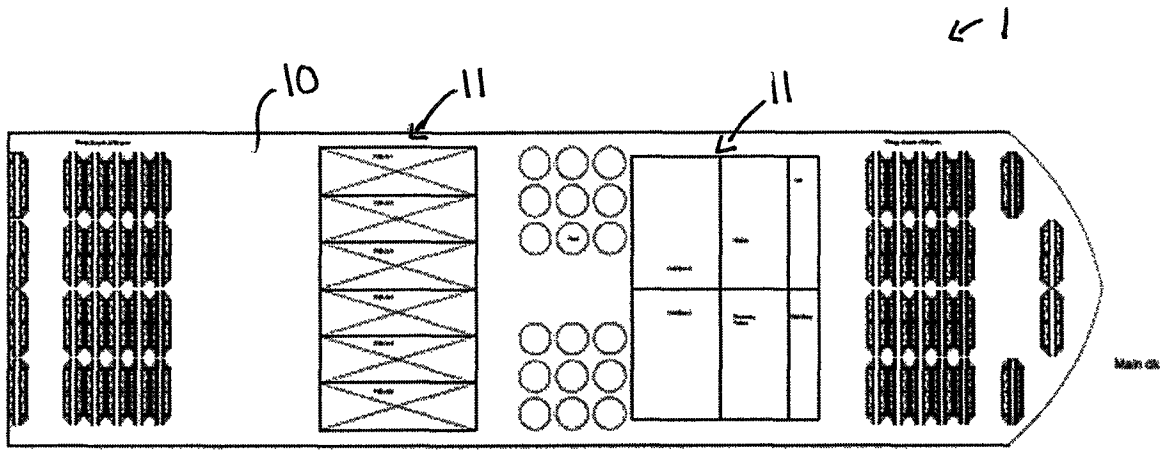

Fig. 4

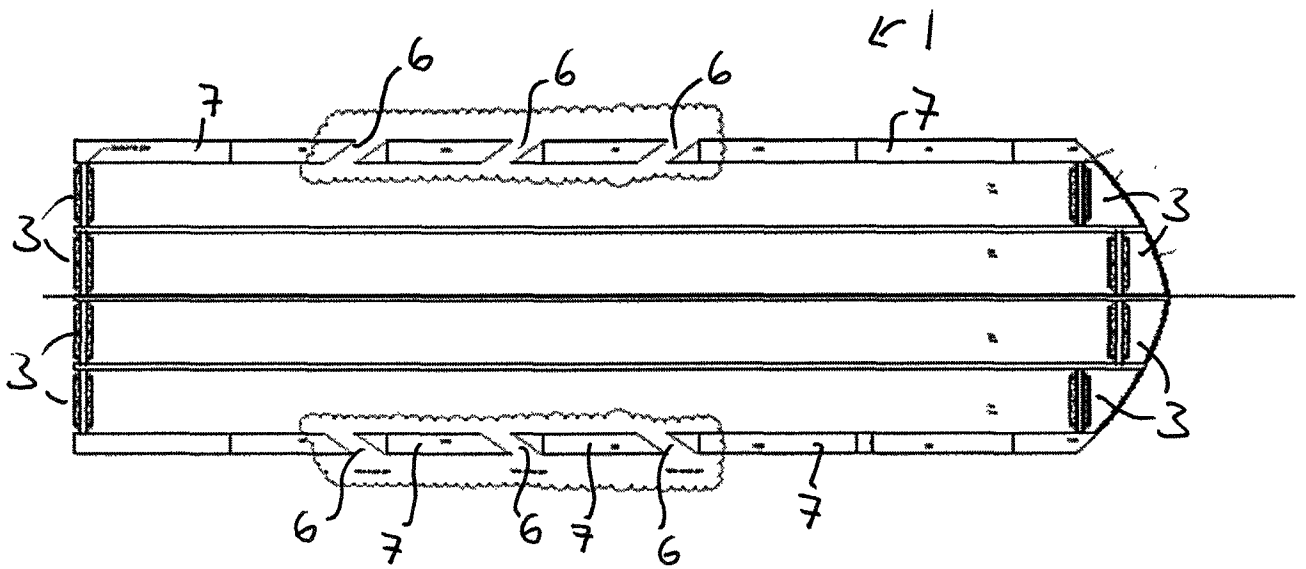

Fig. 5

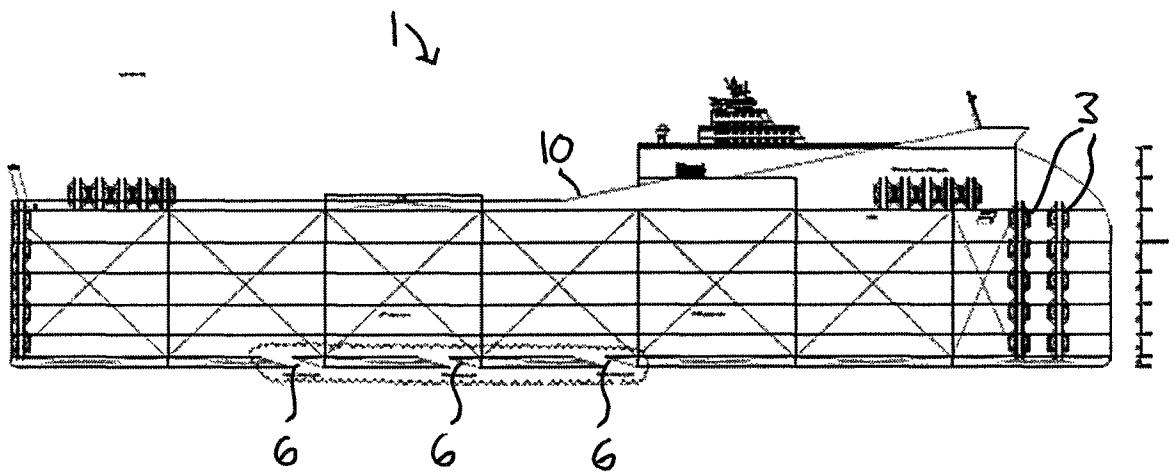

Fig. 6

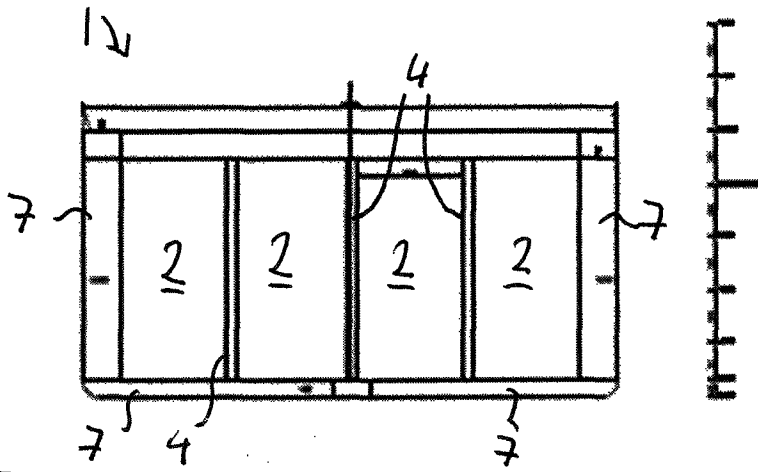

Fig. 7

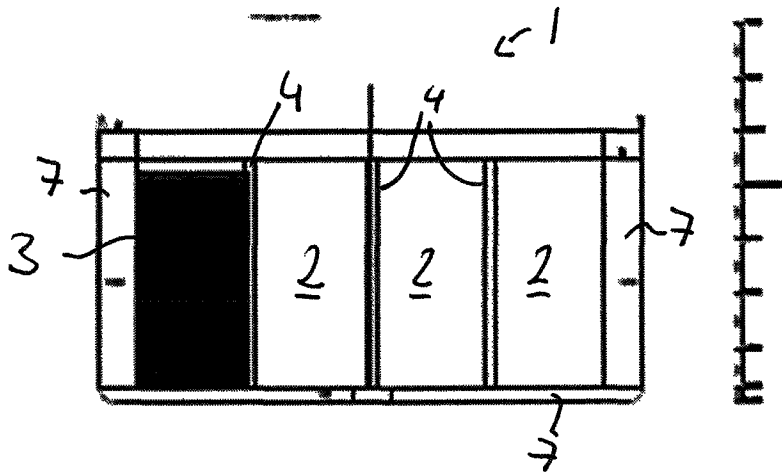

Fig. 8

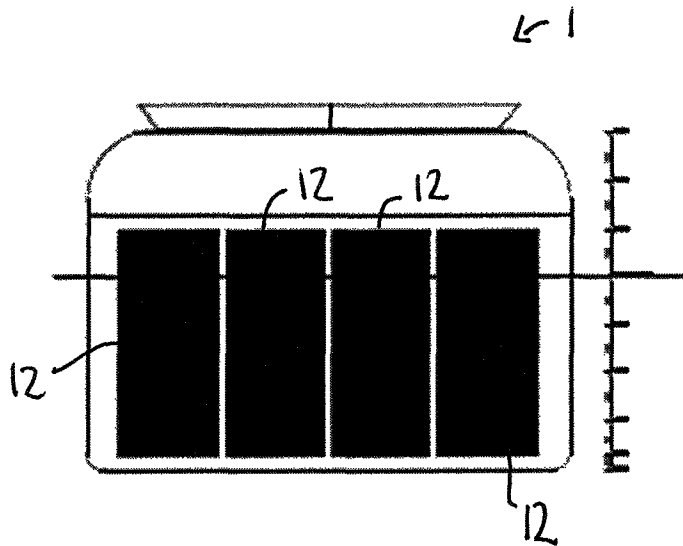

Fig. 9

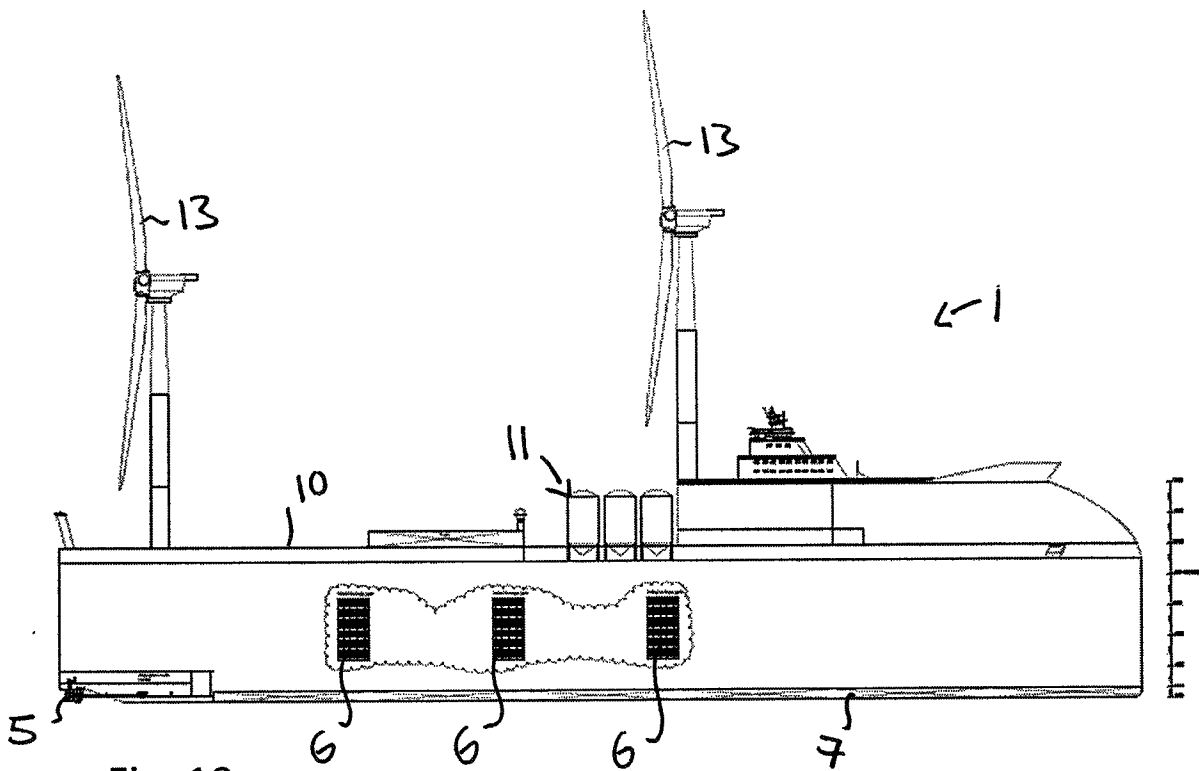

Fig. 10

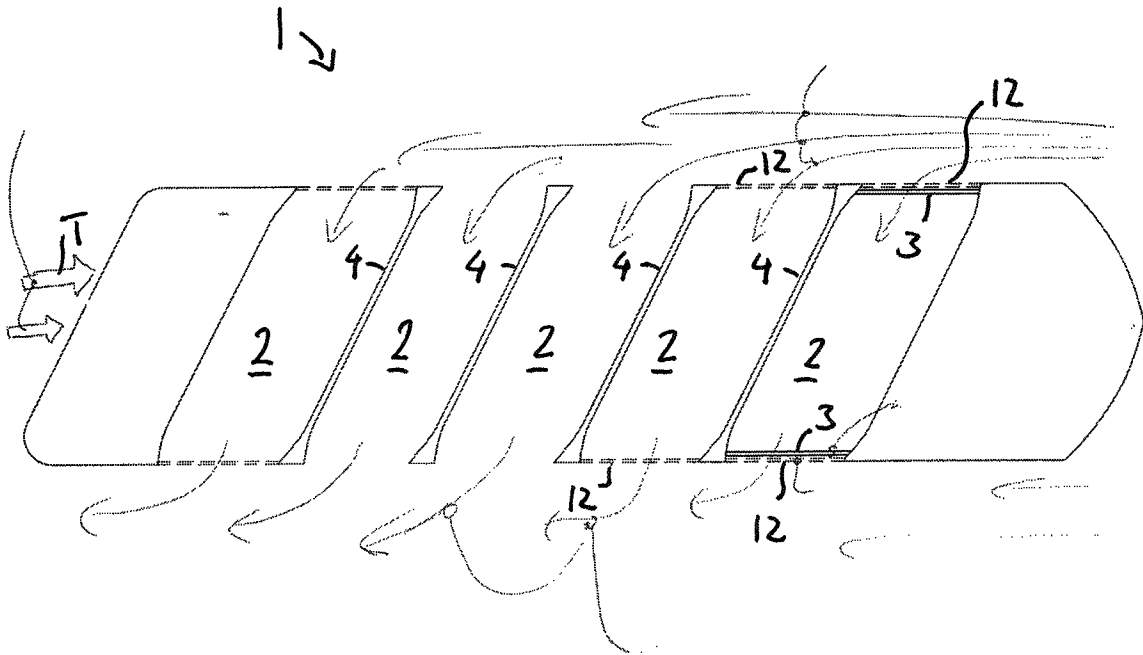

Fig. 11

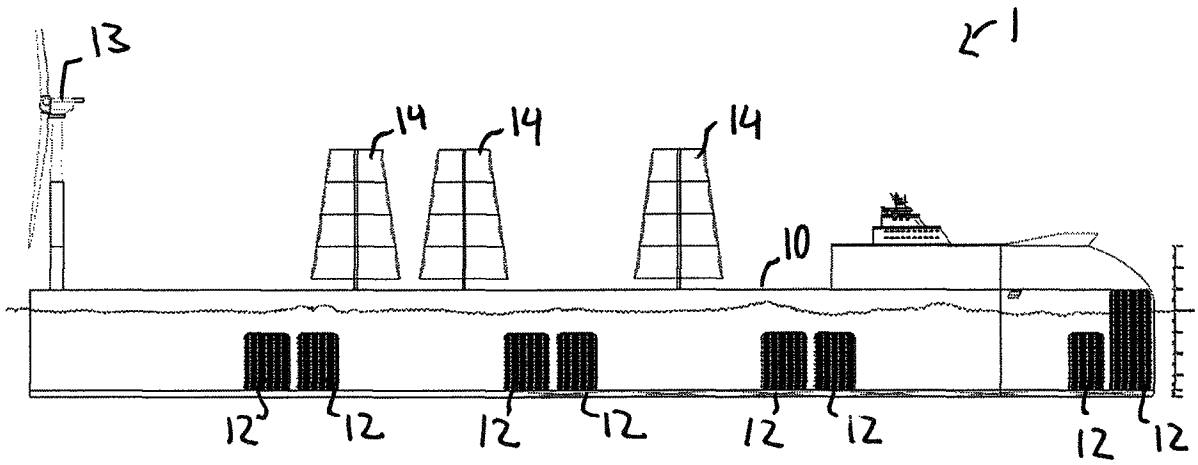

Fig. 12

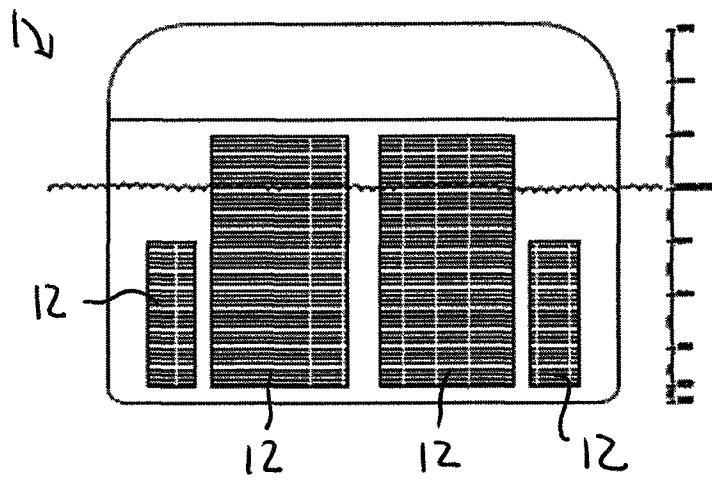

Fig. 13

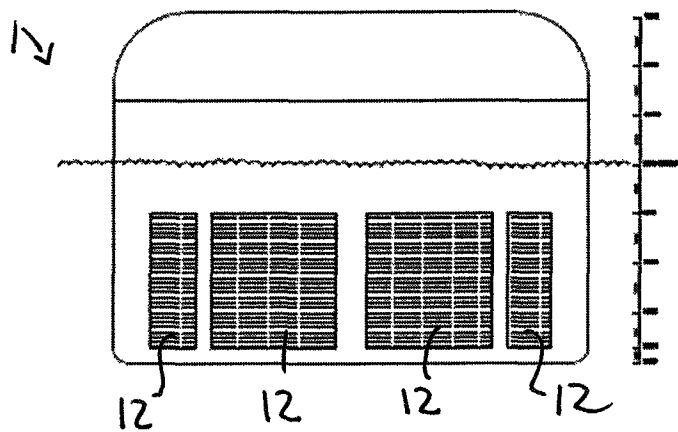

Fig. 14

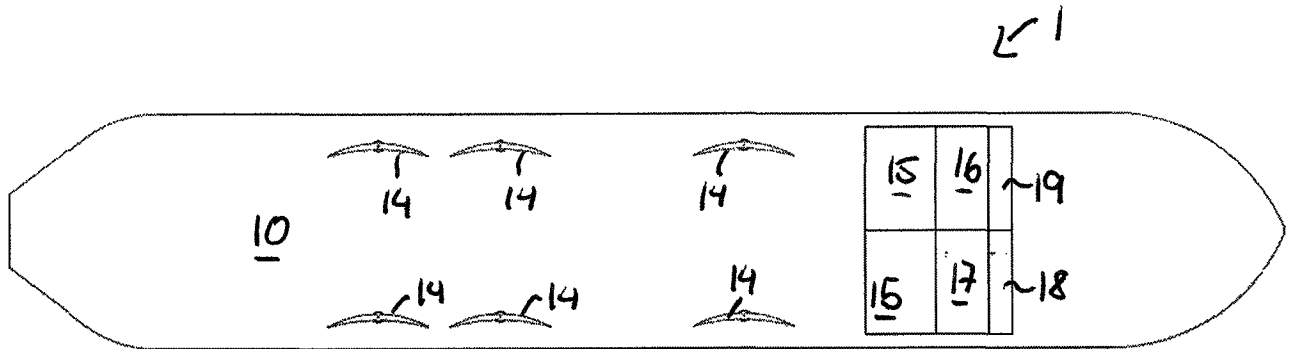

Fig. 15

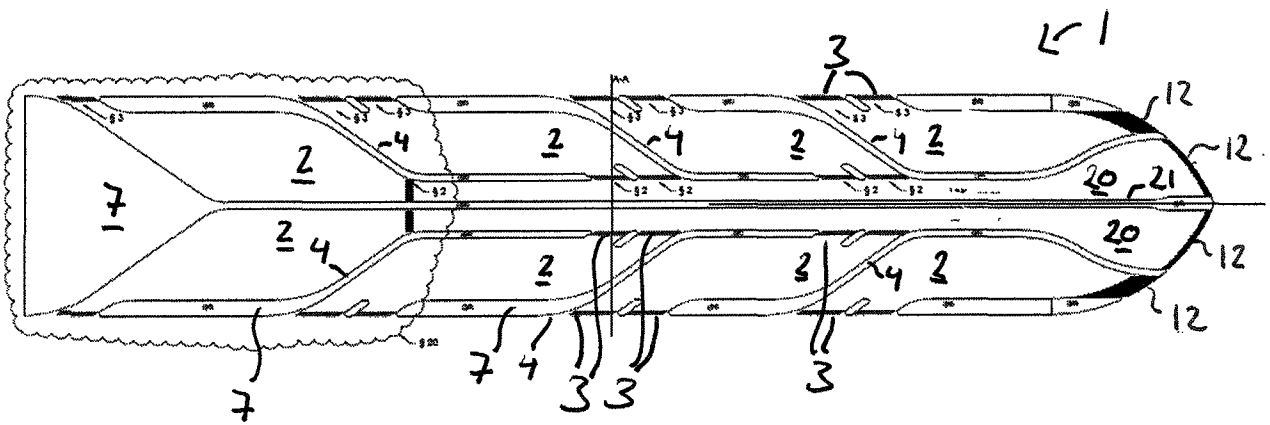

Fig. 16

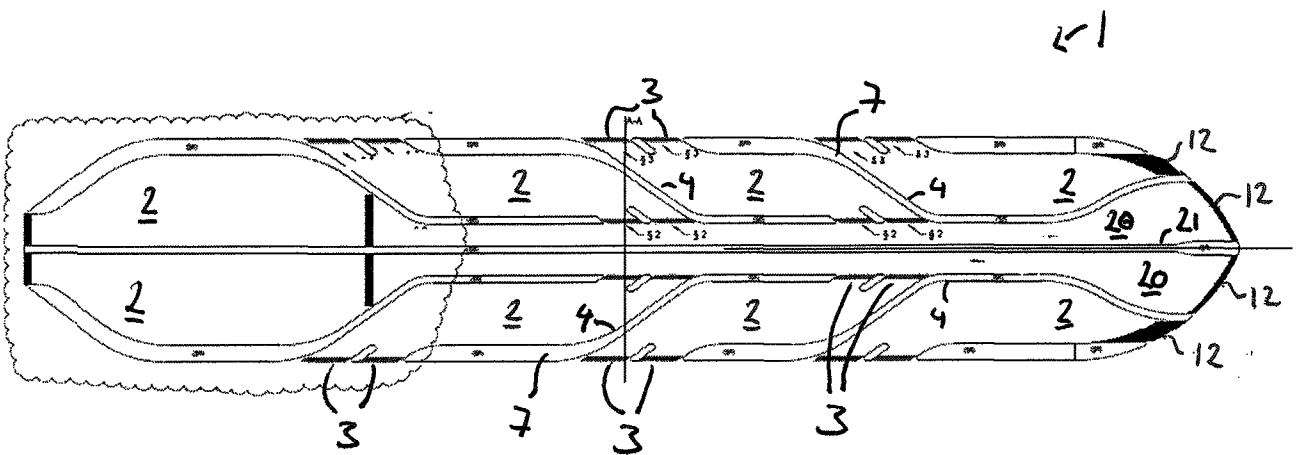

Fig. 17

7/7

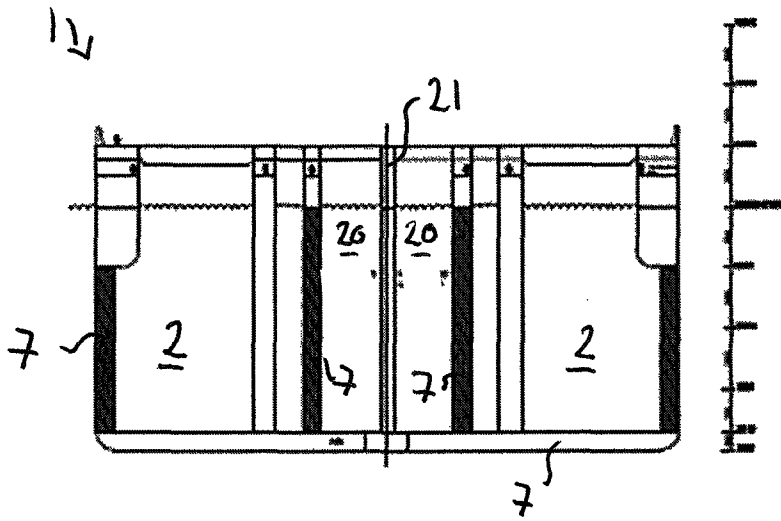

Fig. 18