

Applicant

Dr. ing. Børge Bjørneklett

Vollsveien 216

1359 Eiksmarka

Inventor

Børge Bjørneklett

Invention Name

Photovoltaic System for Offshore Deployment

Photovoltaic system for offshore deployment

Abstract

Methods and systems for construction of marinised photovoltaic power plants for harsh conditions are provided. An example of a method includes reinforcement of the photovoltaic modules mechanical capability and ingress protection while lowering the solar cell operating temperature using a heat sink in contact with water. This can also include attachment of the individual PV modules to buoyant mats, strips or hoses making stackable module strings that can be deployed from a vessel. The method can also include arrangement and mooring of multiple module strings in arrays to power stationary offshore rigs, fish farms, lighthouses or other power demanding installations in marine environment.

DESCRIPTION

FIELD OF THE INVENTION

The present invention relates to renewable energy production utilising modified photovoltaic modules in a floating array system designed for harsh environment offshore.

BACKGROUND OF THE INVENTION

Most fixed or floating offshore units such as oil and gas production platforms, drilling or processing installations require considerable amounts of energy to operate. Other power demanding installation maybe large fish farms that are located far from the grid. The energy demand for these sites are normally supplied via diesel or gas turbine generators. Due to the high energy consumption originating from fossil fuel sources and the subsequent release of carbon dioxide, the activity has raised considerable concern among environmentalists and politicians.

It has been suggested to connect several installations to the regular electricity grid through a land based cable and thereby reduce the CO₂ footprint of the activity. This type of subsea cable is not only technically challenging but also extraordinarily expensive. Hence, the topic is subject to political dispute.

The present invention provides an alternative solution the problem by offering a cost effective and reliable system for harvesting completely renewable energy from photovoltaic devices during the daytime in remote offshore locations. The system can replace a substantial part of the energy demand during daytime in the spring, summer and autumn. PV works well in hybrid power systems where flexible fuel based generators easily can level out the typical irregularities that occur with the shifting output from solar energy systems due to clouds and the position of the sun. Alternatively, batteries may also be used for energy storage. The long Norwegian coastline with its many fjords, as well as the Norwegian sea and continental shelf represent an ideal location for the invention.

The standard 60 or 72 cell photovoltaic module for use in large power plants are not directly designed to withstand mechanical forces that may occur from wave slamming and/or strong winds at sea. Moreover, the modules normally require solid racks that are securely fixed to the ground. Installation racks could in theory be arranged on barges or other floating vessels, but not without a substantial cost penalty compared to e.g. the large scale land based installations.

The present invention provides a novel solution to the problem of installing PV modules in harsh offshore environment at a low installation cost.

Another well-known phenomenon pertaining to photovoltaic modules, is the reduced power production caused by heating of the encapsulated solar cells. The current invention provides an integral solution for cooling the PV device, enabling a low cell operating temperature which increases the energy efficiency.

Yet another advantage with the current invention is the dampening of waves that has a beneficial effect on many offshore installation. Dampening of waves, similar to the effect of oil on troubled waters or wave dampening from e.g. grease ice can have a profound influence on working environment and/or the overall fatigue life of offshore constructions. The invention can work well in combination with offshore wind parks where access to and from the windmills may be troublesome in rough sea. PV also work well in combination with wind power due to overlapping power generation weather conditions during e.g. low wind and high solar radiation and vice versa. For such locations floating PV may also connect to existing power cable infrastructure to land.

SUMMARY OF THE INNVENTION

The gist of the present invention is based on multiple stiff and ruggedized PV modules, essentially having an IP (Ingression Protection) grade of 68 or better, which are interconnected in strings and installed onto large, thin, flexible and buoyant mats or strips which float in the sea. The substrate mats or elongated strips are fully flexible and essentially follows the motion of the sea waves. Chopped waves and sea spray is effectively hampered by the presence of the mats which may cover large areas. The mats may or may not be perforated or have recesses to allow drainage of accumulated pools of water while maintaining a thin film of water on top. The mats can be constructed from crosslinked closed cell foam from e.g. polyethylene, polyurethane, EVA, synthetic rubber or copolymers which can be fabricated in large sections and that provide adequate buoyancy and impact protection. Alternatively, the fabric may also be multi-layered and or partially inflated by pockets of gas or buoyant oils or jellies etc. The PV modules will be fixed to the mats with e.g. quick lock carabiners or shackles which are attached to pad eyes that are securely welded or integrated in the mats. Alternative fixation means can be by straps or e.g. sewed pockets etc. However, many fixation methods can be envisaged without deviating from the original spirit of the idea.

The relatively thin silicon based solar cells in PV modules are by nature brittle and vulnerable to fracturing. In order to eliminate the problem of fracturing caused by repeated motion generated by sea waves and/or slamming forces, the modules must be reinforced. Reinforcement can be achieved by adding a stiffening core material to the backside of the module This will essentially create a very stiff module, increasing the bending resistance and the effective bending radius of the laminated solar cells and hence avoid excessive damage.

Normally, the backside of the PV module is open to air circulation in order to avoid thermal insulation which cause the cells to heat up and become less efficient. With the present invention, this problem is addressed by letting the backside be thermally connected to the sea water. This can be achieved by attaching an aluminium heat sink to the backside of the panel. The favourable effect of water cooling of solar cells as such is already well established and known in the industry. The stiffening core material may also be equipped with cooling channels to allow thermal dissipation directly to water. The composite core material may also preferentially be selected of a material with a beneficial thermal conductivity.

The offshore PV array is designed with enough buoyancy to float, with the backside of the PV modules partially submerged, enabling heat transfer with the water. The module strings, or multiple strings forming an array, are moored to the seabed, by anchors, chains and in combination with light weight rope made of e.g. polyester or nylon. Alternative means of mooring is of course also possible.

Buoys are also installed to prevent the PV installation to be dragged under by sea current and/or wave drift forces. The geometry as well as the number and size of the anchors and buoys is designed to minimise lateral drift forces. The buoys may also be equipped with appropriate lanterns to mark the location of the power plant for seafarers.

An important aspect of the invention is the easy attachment of the PV modules which enable quick and cost efficient installation by deploying PV modules attached to flexible mats, strips of mat or hoses on to the surface from suitable vessels. The modules are stackable and can easily be deployed or retracted in case of extreme weather. The PV modules are interconnected with high quality non degradable contacts capable of permanent submersion. Furthermore, the electrical cables are mechanically attached to the rigid module in order to strengthen the stress relief properties beyond what is offered by the regular junction box terminals.

Depending on the size of the PV array, number of strings, designed peak wattage etc., the PV system is connected to inverters capable of transforming the power to the intended offshore consumer. If the inverters and transformers or not installed directly at the user's offshore facility, they can be encapsulated and made buoyant. The latter is particularly relevant for large area installation with e.g. multiple string inverters and where the power is delivered through a main power cable to the end user.

In one embodiment of the invention, preassembled strings of modules can be stacked on deck of vessels or barges for easy deployment or retraction e.g. for winter, in order to avoid the most extreme weather and to preserve the system when the power generating potential is lower due to limited daylight. Alternatively, the PV system can be seasonably operated and towed to more benign waters e.g. fjords during winter. In more equatorial waters the installations can be operated under similar insolation conditions year round. The horizontal arrangement of modules is ideal for near vertical insolation around equatorial waters, but the floatation system or the modules themselves can alternatively be fabricated with fixed inclination, e.g. 20 -30 degrees for optimisation in the northern or southern hemisphere. The latter require proper orientation of the floating array.

The system may also be combined with batteries and preferably be used in combination with low energy density redox flow battery technology.

Several large arrays will have a calming effect on the sea in the vicinity of the offshore installations, similar to that of oil slicks or grease ice in troubled waters. The PV system which essentially covers the surface of the sea will prevent wind induced breaking of waves, ripples and chopped sea, while the individual PV modules will experience slow heave motion when subjected to large swells.

BRIEF DESCRIPTION OF THE DRAWINGS

FIG. 1 Diagrammatic view of photovoltaic system floating in the sea

FIG. 2 Showing PV module attached to perforated floatation mat

FIG. 3 showing a first embodiment—is a cross section of a PV module with stiffening element containing a heat sink

FIG. 4 Showing a second embodiment—a similar cross section where the stiffening cooling element consists of a corrugated profile

DETAILED DESCRIPTION OF SPECIFIC EMBODIMENTS

Fig 1. (Not to scale) Show an example of interconnected PV modules [1] installed onto elongated flexible floating mats [2] which are attached to buoys [3] which are moored with polyester or nylon ropes [4] which again is secured to the seabed by anchors [5].

FIG. 2 (Not to scale) Showing a PV module with frame for attachment points [8] for attachment to the perforated floatation mat with pad eyes [9] using shackles [10].

FIG. 3 Showing one embodiment - Cross-section of the ruggedized PV module with laminate [12] encapsulating silicon based solar cells [13]. The module is modified with lightweight sandwich composite core material [6] and heat sink elements [7]. The heat sink is arranged to facilitate heat dissipation from the backside of the laminate to the sea.

FIG. 4. Showing a second embodiment where the heat sink is made of aluminium profile or corrugated heat sink plate [11] fixed to the aluminium frame [8].

CLAIMS (9)

The invention claimed is:

1. A method of constructing a photovoltaic energy plant in marine offshore environment comprising the steps of:

Operationally deploying a plurality of photovoltaic module strings [2] from a vessel to form an offshore renewable energy power plant;

Installing reinforced and marinised PV modules [1] to elongated buoyant mats which are affixed to individual buoys [3] that are anchored to the seabed to form a photovoltaic array capable of power production in rough seas offshore

Performing one or more of the following steps:

Improving the mechanical stiffness of PV modules [1] to withstand rough sea by introducing a reinforcement element [6] attached to the backside of the laminate, and

providing a heat sink [7] sandwiched between the backside of the module [1] and the stiffening element [6]

Attaching a plurality of modules to flexible installation mats forming an interconnected module string [2]

2. A method as defined in claim 1, where strings of modules are preassembled on shore, folded, stacked and deployable from a vessel
3. A method as defined in claim 1, where strings of modules are electrically connected to a floating water-cooled DC/AC inverter
4. A method as defined in claim 1, where strings of modules are electrically connected to floating DC combiner units
5. A method as defined in claim 1, wherein the PV installation mats are made of closed cell polymer foam
6. A method as defined in claim 1, wherein the foldable PV installation mats is constructed of synthetic rubber

7. A method according to claim 4, where the installation mats are inflatable with gas or biodegradable oil
8. A method as defined in claim 1, wherein the heat sink is constructed of marine grade aluminium alloy
9. A method as defined in claim 5. Where the heat sink is thermally connected to the module frame

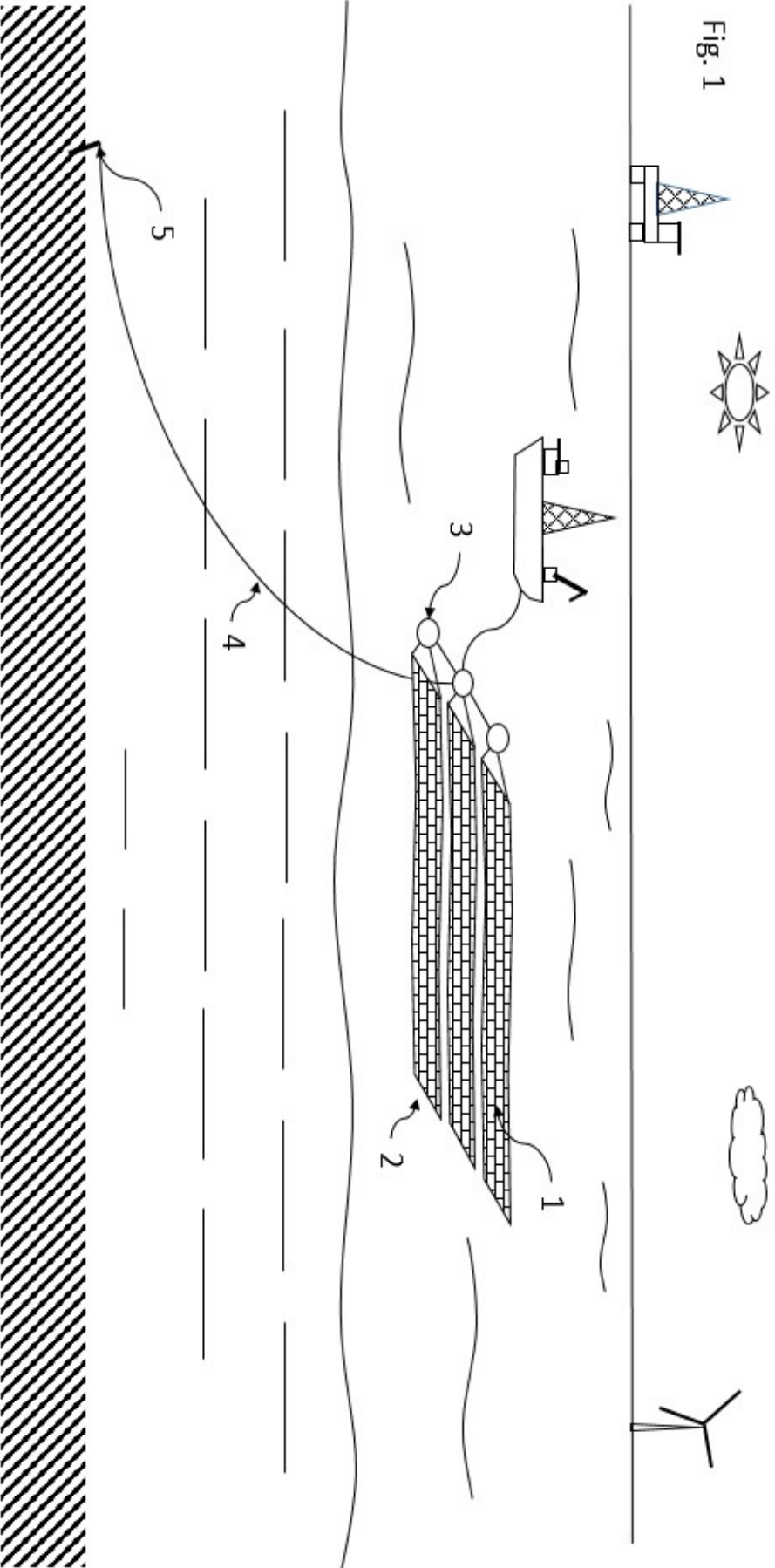

Fig. 1

Fig. 2

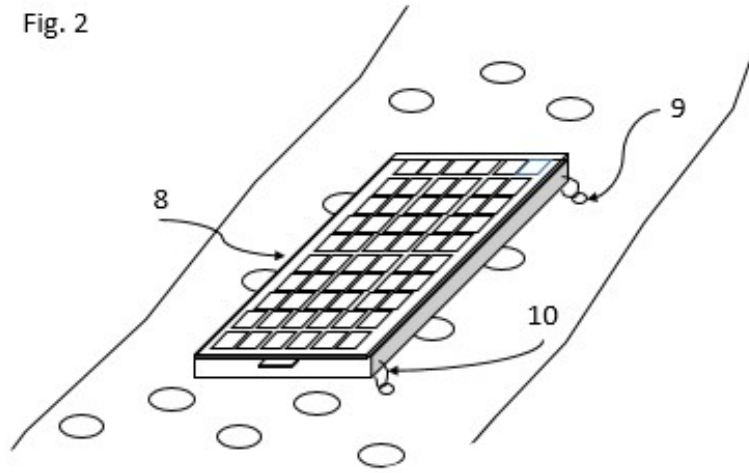

Fig. 3

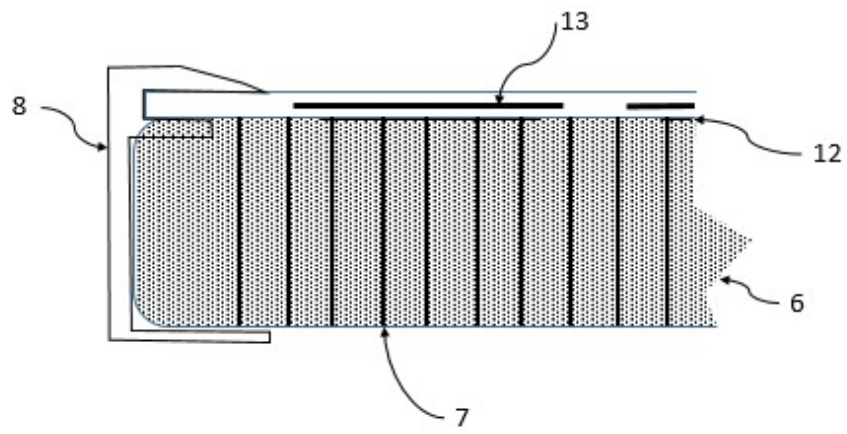

Fig. 4

